

**X HOVER-1™**

**i-100**



OPERATION MANUAL  
H1-100

# HELMETS SAVE LIVES!

Always wear a properly fitted helmet that complies with CPSC or CE safety standards when you ride your scooter.



**Correct Fitting:**

Make sure your helmet covers your forehead.

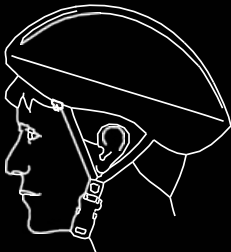

**Incorrect Fitting:**

Forehead is exposed and vulnerable to serious injury.

# **WARNING!**

## **PLEASE READ THE USER MANUAL THOROUGHLY.**

**Failure to follow the basic instructions and safety precautions listed in the user manual can lead to damage to your device, other property damage, serious bodily injury, and even death.**

Thank you for purchasing the i-100 Electric Scooter. Please read all instructions carefully before using and retain this manual for future use and reference.

This manual applies to the i-100 Scooter.

- In order to avoid dangers that are caused by collisions, falls, and loss of control, please learn how to ride the i-100 safely.
- You can learn operating skills by reading the product manual and watching videos.
- This manual includes all operating instructions and precautions, and users must read it carefully and follow the instructions.
- Hover-1 can not be held liable for damage or injury caused by failure to understand and follow the warnings and instructions in this manual.

### **ATTENTION**

1. Use only the supplied charger with this scooter.

Charger Manufacturer: SHENZHEN FUYUANDIAN POWER CO LTD

Model: FY0422941000

2. The operating temperature range of the i-100 is 32-104° F (0-40° C).
3. Do not ride on icy or slippery surfaces.
4. Read the user manual and warning labels before riding.
5. Store the i-100 in a dry, ventilated environment.
6. When transporting the i-100, avoid violent crashes or impact.

## **LOW TEMPERATURE WARNING**

Low temperature will affect the lubrication of moving parts inside the i-100 scooter, increasing internal resistance. At the same time, in low temperatures, the discharge capacity and the capacity itself of the battery will be significantly decreased.

Use caution when riding the i-100 in cold temperatures (below 40 degrees F).

Doing so may increase the risk of mechanical failures of the scooter, which may lead to damage to your device, other property damage, serious bodily injury and even death.

## **SAFETY INSTRUCTIONS**

- Keep the device away from heat sources, direct sunlight, humidity, water and any other liquids.
- Do not operate the device if it has been exposed to water, moisture or any other liquids to prevent against electric shock, explosion and/or injury to yourself and damage to the device.
- Do not use the device if it has been dropped or damaged in any way.
- Repairs to electrical equipment should only be performed by the manufacturer. Improper repairs voids the warranty and may place the user at serious risk.
- Do not puncture or harm the exterior surface of the product in any way.
- Keep the device free from dust, lint, etc.
- Do not use this device for anything other than its intended use or purpose. Doing so may damage the device or lead to property damage, injury or death.
- This product is not a toy. Keep out of reach of children.
- Do not expose batteries, battery pack, or batteries installed to excessive heat, such as direct sunlight, or open flame.
- Do not allow hands, feet, hair, body parts, clothing or similar articles to come in contact with moving parts, wheels or drive train, while the engine is running.

- Do not operate or allow others to operate the i-100, until the user understands all instructions, warnings and safety features described in this manual.
- Check with your doctor if you have a medical condition that could affect your ability to use the i-100.
- Persons with head, back or neck ailments or prior surgeries to those areas of the body are not recommended to use the i-100.
- Do not operate if you are pregnant, have a heart condition, or have both.
- Persons with any mental or physical conditions that may make them susceptible to injury or impair their physical or mental capabilities to recognize, understand and perform all of the safety instructions and to be able to assume the hazards inherent in unit use, should not use the i-100.



## NOTES:

In this manual, the above symbol with the word "NOTES" indicates instructions or relevant facts the user should remember prior to using the device.



## CAUTION!

In this manual, the above symbol with the word "CAUTION" indicates a hazardous situation which, if not avoided, can cause minor or moderate injury.



## WARNING!

In this manual, the above symbol with the word "WARNING" indicates a hazardous situation which, if not avoided, can cause death or serious injury.

## SERIAL NUMBER

Please keep the serial number on file for warranty claims as well as proof of purchase.



## WARNING!

**WARNING:** Prolonged Exposure to UV Rays, Rain and the Elements  
May Damage the Enclosure Materials.  
Store Indoors When Not in Use

# INTRODUCTION

The i-100 is a personal transporter. Our technology and production processes are developed with strict testing for each i-100 scooter. Operating the i-100 without following the contents of this manual may lead to damage to your i-100, or bodily injury.

This manual is designed to give you the information you need for the safe operation and maintenance of your i-100. Please read it thoroughly before riding your i-100.

## PACKAGE CONTENTS

- Hover-1 i-100 Electric Scooter
- Wall Charger
- Operation Manual

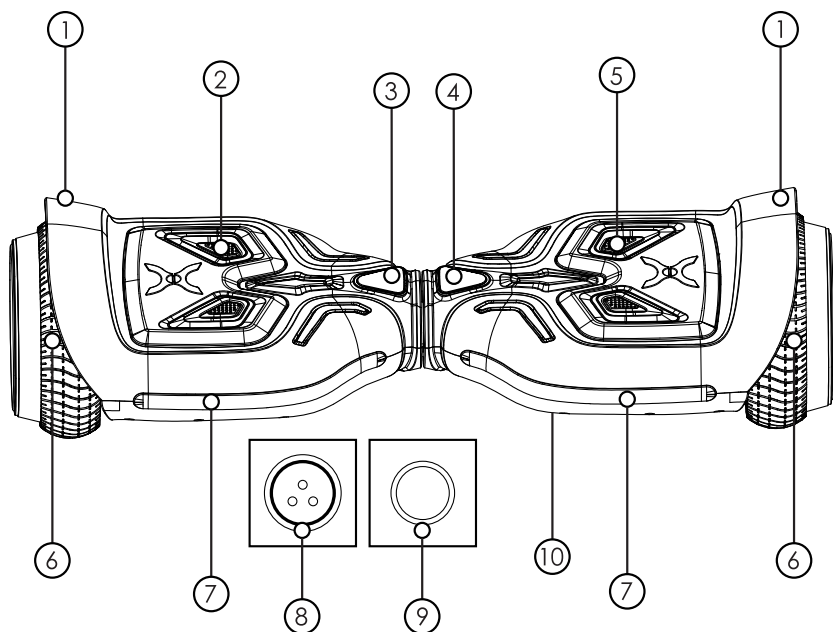

## FEATURES/PARTS

- |                      |                                   |
|----------------------|-----------------------------------|
| 1. Fender            | 6. Tire                           |
| 2. Right Foot Mat    | 7. LED Light                      |
| 3. Battery Indicator | 8. Charge Port (located in rear)  |
| 4. Running Indicator | 9. Power Button (located in rear) |
| 5. Left Foot Mat     | 10. Wireless Speaker              |

## OPERATING PRINCIPALS

The device uses digital electronic gyroscopes and acceleration sensors to control balance and motion, depending on the user's center of gravity. The device also uses a control system to drive the motors that are located within the wheels. The device has a built-in inertia dynamic stabilization system that can help assist with balance when moving forward and backwards, but not while turning.

TIP – To increase your stability, you must shift your weight in order to overcome the centrifugal force during turns, especially when entering a turn at higher speeds.

## **WARNING**

Any i-100 that does not work properly can cause you to lose control and fall. Inspect the entire device thoroughly before every ride, and do not ride it until any problems have been corrected.

## SPECIFICATIONS

Model:	Hover-1™ i-100 (H1-100)
Net Weight:	16.3 lbs (7.4 kg)
Load:	44-220 lbs (20-100 kg)
Max Speed:	Up to 7 mph (11.26 km/h)
Max Distance Range:	Up to 10 miles (16.09 km)
Max Incline Angle:	10°
Minimum Turning Radius:	0°
Battery Type:	Lithium-ion
Battery Voltage:	25.2 V
Battery Capacity:	4.0 Ah
Power Requirement:	AC 100-240V, 50/60 Hz
Wheel Size:	6.5 Inches (16.51 cm)
Tire Type:	Non-Pneumatic Solid Tires
Bluetooth Range:	Up to 33ft
Bluetooth Speaker:	V2.0 with stereo sound quality
UL Certification:	UL 2272 approved
Contains FCC ID:	2AANZRCKR
BT ID:	D042258

# CONTROLS AND DISPLAY

**PLEASE READ THE FOLLOWING INSTRUCTIONS CAREFULLY**

## **TURNING YOUR DEVICE ON/OFF**

**Power On:** Take your device out of the box and place it flat on the floor. Press the power button (located on the rear of your device) once. Check the LED indicator (located in the center of your device). The battery indicator light should be lit, indicating the device is powered on.

**Power Off:** Press the power button once.

## **MAT SENSOR**

There are four sensors under the foot mats on your i-100. When the user steps off the scooter mats, it will automatically initiate self-calibration.

When riding the scooter, you must ensure you are stepping on the foot mats. Do not step or stand on any other area of your scooter.

The i-100 may vibrate or spin in one direction, if weight and pressure are applied to only one foot mat.

## **BATTERY INDICATOR**

The display board is located in the middle of the i-100 scooter.

- Green LED Light indicates the hoverboard is fully charged.
- Red flashing LED light and beeping indicates low battery.
- Yellow light indicates the board is charging.

When the LED light turns red, please recharge the device.

## **RUNNING INDICATOR**

When the operator triggers the foot mats, the Running Indicator LED will light up, which means that the system enters the running state.

When the system has an error during operation, the running LED light will turn red (for more details see SAFETY ALERTS).



# BLUETOOTH SPEAKER

The i-100 has a powerful built-in wireless speakers so you can play your music while riding.

## PAIRING THE SPEAKER

- 1) Turn on your i-100 and the speakers will "Ping" to announce that it's waiting for a Bluetooth® connection. This will indicate your i-100 speaker is now in pairing mode.
- 2) Place the i-100 and the Bluetooth® device to which you would like to pair it within the operating distance. We recommend keeping the two devices no further than 3 feet apart during pairing.
- 3) Ensure Bluetooth® is enabled on your phone or music device. Refer to manufacturer's instructions for how to enable Bluetooth® on your device.
- 4) Once you have activated Bluetooth® on your device, select the option "H1-100" from the list of available Bluetooth® devices.
- 5) If required, enter the PIN code "000000" and confirm the entry.
- 6) The i-100 will say "Paired" when successfully paired.
- 7) Please note, pairing mode on the i-100 will last for two minutes. If no devices are paired after two minutes, the i-100 speaker will automatically return to standby mode.
- 8) If pairing is unsuccessful, turn off the i-100 first and re-pair following the aforementioned steps.
- 9) If your smart phone is out of range, or the battery is low on your i-100, your speaker may disconnect from your smart device, and the i-100 will say "Disconnected." To reconnect, follow the aforementioned steps, or recharge your scooter.

NOTE: Once you have paired the i-100 speaker with a device, the speaker will remember this device and will pair automatically when the device's Bluetooth® is activated and in range. You do not need to re-pair any previously connected devices.

Your scooter can pair up to two multi-point devices. You can reconnect a previously paired device without going through the pairing or PIN process on up to two devices.

## LISTENING TO MUSIC

Once the i-100 Bluetooth speaker is paired to your device, you can stream music wirelessly through it. Only one speaker will play music as the other speaker is strictly for safety alerts from your Hover-1. Select the track you wish to listen to on your device to listen via the speaker. All volume and track controls will be made using your music device. Should you encounter any problems while streaming, please refer to your device's user manual.

# SMART PHONE APP

Your i-100 is an App-enabled scooter that works with Apple iOS and Android devices. Download the free Hover-1 App in order to access certain features of your i-100 such as headlight colors and skill mode.

Using a QR code reader, hold the camera on your smartphone over the below QR code to download the Hover-1 App. Feel free to search "Hover-1" in your device App store.



For IOS



For Android

# BEFORE RIDING

It is important that you fully understand all elements of your i-100. If these elements are not used correctly, you will not have full control of your i-100. Before you ride, learn the functions of the various mechanisms on your scooter.

Practice using these elements of your i-100 at slower speeds in a flat, open area before taking the device out in public areas.

## PRE-RIDE CHECKLIST

Ensure that your i-100 is in proper working order each and every time you ride. If a part of the scooter does not function correctly, please contact our Customer Support Center.

### **WARNING**

Any i-100 that does not work properly can cause you to lose control and fall. Do not ride a i-100 with a part that is damaged; replace the damaged part before riding.

- Ensure the battery is fully charged before riding your scooter.
- Please wear all appropriate safety and protective gear as previously mentioned in the User Manual before operating your i-100.
- Make sure to wear comfortable clothes and flat closed-toe shoes when operating your device.
- Please carefully read the User Manual, which will assist in explaining the basic working principles and provide tips on how to best enjoy your experience.

# SAFETY PRECAUTIONS

Different localities and countries have different laws governing riding on public roads, and you should check with local officials to ensure you are complying with these laws.

Hover-1 is not liable for tickets or violations given to riders who do not follow local laws and regulations.

- For your safety, always wear a helmet that meets CPSC or CE safety standards. In the event of an accident, a helmet can protect you from serious injury and in some cases, even death.
- Obey all local traffic laws. Obey red and green lights, one-way streets, stop signs, pedestrian crosswalks, etc.
- Ride with traffic, not against it.
- Ride defensively; expect the unexpected.
- Give pedestrians the right-of-way.
- Do not ride too close to pedestrians and alert them if you intend to pass them from behind.
- Slow down at all street intersections and look to the left and right before crossing.

Your i-100 is not equipped with reflectors. It is not recommended that you ride in conditions of low visibility.

## **WARNING**

When you ride in low-visibility conditions such as fog, dusk, or night, you might be difficult to see, which could lead to a collision. In addition to keeping your headlight on, wear bright, reflective clothing when riding in poor lighting conditions.

Think about safety when you ride. You can prevent many accidents if you think about safety. Below is a helpful checklist for Compact riders.

## SAFETY CHECKLIST

- Do not ride above your skill level. Ensure you have had enough practice with all functions and features of your i-100.
- Before stepping on your i-100, make sure it is placed flat on level ground, the power is on, and the Running Indicator light is green. Do not step on if the Running Indicator light is red.
- Do not try to open or modify your i-100. Doing so, voids the manufacturer warranty and may cause your i-100 to fail, resulting in injury or death.
- Do not use the i-100 in a manner that would put people or property in danger.
- If riding near others, keep a safe distance to avoid collision.
- Be sure to keep your feet on the pedals at all times. Moving your feet off your i-100 while driving is dangerous and may cause the i-100 to stop or veer sideways.
- Do not operate the i-100 while under the influence of drugs and/or alcohol.
- Do not operate the i-100 when you are restless or sleepy.
- Do not ride your i-100 off of curbs, ramps, or attempt to operate in a skate park, empty pool, or in any way similar to a skateboard or scooter. The i-100 IS NOT A SKATEBOARD. Misuse of your i-100, voids the manufacturer warranty and may lead to injury or damage.
- Do not continuously spin in place, it will cause dizziness and increases risk of injury.
- Do not abuse your i-100, doing so can damage your unit and cause failure to the operating system leading to injury. Physical abuse, including dropping your i-100, voids the manufacturer warranty.
- Do not operate in or near puddles of water, mud, sand, stones, gravel, debris or near rough and rugged terrain.
- The i-100 can be used on paved surfaces that are flat and even. If you encounter uneven pavement, please lift your i-100 over and past the obstruction.
- Do not ride in inclement weather: snow, rain, hail, sleet, on icy roads or in extreme heat or cold.

- Bend your knees when riding on bumpy or uneven pavement to absorb the shock and vibration and help you keep your balance.
- If you are unsure if you can safely ride on a specific terrain, step off and carry your i-100. ALWAYS BE ON THE SIDE OF CAUTION.
- Do not attempt to ride over bumps or objects greater than ½ in, even when prepared and bending your knees.
- PAY ATTENTION - look at where you are riding and be conscious of the road conditions, people, places, property and objects around you.
- Do not operate the i-100 in crowded areas.
- Operate your i-100 with extreme caution when indoors, especially around people, property, and narrow spaces.
- Do not operate the i-100 while talking, texting, or looking at your phone.
- Do not ride your i-100 where it is not permitted.
- Do not ride your i-100 near motor vehicles or on public roads.
- Do not travel up or down steep hills.
- The i-100 is intended for use by a single individual, DO NOT attempt to operate the i-100 with two or more people.
- Do not carry anything while riding the i-100.
- Individuals with lack of balance should not attempt to operate the i-100.
- Pregnant women should not operate the i-100.
- The i-100 is recommended for riders ages 15 and older.
- At higher speeds, always take into consideration longer stopping distances.
- Do not step forward off of your i-100.
- Do not attempt to jump on or off your i-100.
- Do not attempt any stunts or tricks with your i-100.
- Do not ride the i-100 in dark or poorly lit areas.

- Do not ride the i-100 off road, near or over potholes, cracks or uneven pavement or surfaces.
- Keep in mind that you are 4.5 inches (11.43 cm) taller when operating the i-100. Make sure to go through doorways safely.
- Do not turn sharply, especially at high speeds.
- Do not step on the fenders of the i-100.
- Avoid driving the i-100 in unsafe places, including near areas with flammable gas, steam, liquid, dust, fiber, which could cause fire and explosion accidents.
- Before riding, ensure that tires are in good condition and have sufficient tread remaining.
- Do not operate near swimming pools or other bodies of water.

## **WARNING**

When a hoverboard and a kart (sold separately) are being used, it is NOT ADVISABLE to ride the combo uphill. If using on a steep incline above 5-10°, a safety mechanism built into the hoverboard will activate, which will shut down your hoverboard automatically. If this happens, dismount your hoverboard, place it on a flat surface, wait 2 minutes, and then power your hoverboard on again.

## **WARNING:**

To reduce the risk of injury, adult supervision is required. Never use in roadways, near motor vehicles, on or near steep inclines or steps, swimming pools or other bodies of water; always wear shoes, and never allow more than one rider.

# RIDING YOUR i-100

**FAILURE TO FOLLOW ANY OF THE FOLLOWING SAFETY PRECAUTIONS CAN AND MAY LEAD TO DAMAGE TO YOUR i-100, VOID YOUR MANUFACTURER WARRANTY, LEAD TO PROPERTY DAMAGE, CAUSE SERIOUS BODILY INJURY, AND CAN LEAD TO DEATH.**

Before using your i-100, be sure to familiarize yourself with the operating procedures.

## OPERATING YOUR DEVICE

Make sure the i-100 is fully charged before your initial use. For charging instructions, please follow details under CHARGING YOUR i-100.

Stand directly behind your device and place one foot on the corresponding foot mat (as described in the diagram below). Keep your weight on the foot which is still on the ground, otherwise the device may begin to move or vibrate, making it difficult to step on evenly with your other foot. When you are ready, shift your weight to the foot already placed on the device and step on with your second foot quickly and evenly (as described in the diagram below).

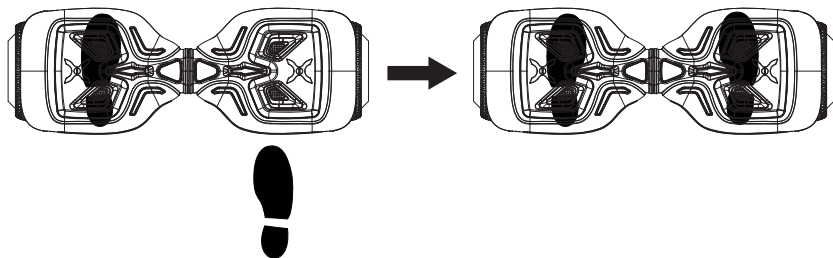

## NOTES:

Stay relaxed and step on quickly, confidently and evenly. Imagine climbing stairs, one foot, then the other. Look up once your feet are even. The i-100 may vibrate or spin in one direction, if weight and pressure are applied to only one foot mat. THIS IS NORMAL.

Find your center of gravity. If your weight is distributed correctly on the foot mats and your center of gravity is level, you should be able to stand on your device just as if you were standing on the ground.

On average, it takes 3-5 minutes just to get comfortable standing on your device and maintaining proper balance. Having a spotter will



help you feel more secure. The i-100 is an incredibly intuitive device; it senses even the slightest bit of motion, so having any anxiety or reservation about stepping on may cause you to panic and trigger unwanted movement.

When you first begin using your device, the fastest way to move in your desired direction is to focus in that direction. You will notice that just thinking about which way you would like to go will shift your center of gravity, and that subtle movement will propel you in that direction.

Your center of gravity determines which direction you move, accelerate, decelerate, and come to a complete stop. As described in the diagram below, tilt your center of gravity in the direction you wish to move.

To turn, focus on the direction you wish to turn and stay relaxed.

**⚠ WARNING**

Do not turn sharply or at high speeds to avoid danger. Do not turn or ride quickly along slopes, as it may cause injury.

As you get comfortable on the device, you will notice it becomes easier to maneuver. Remember at higher speeds, it is necessary to shift your weight to overcome the centrifugal force.

Bend your knees if you encounter bumps or uneven surfaces, then dismount and carry your i-100 to a safe operating surface.

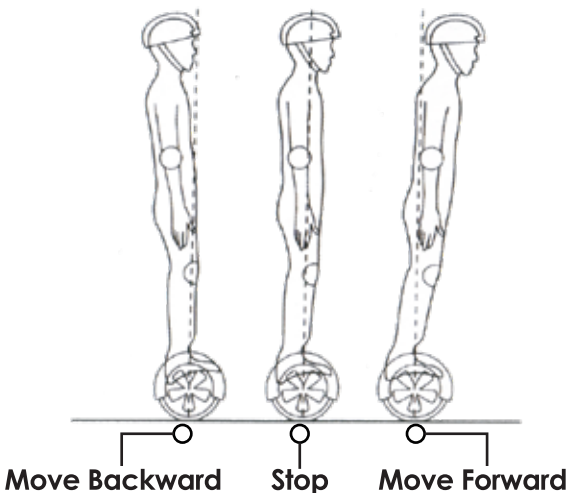



## NOTES:

Try staying relaxed and focus on finding your center of gravity to maintain full control of your i-100.

Dismounting your device can be one of the easiest steps, yet when done incorrectly, may cause you to fall. To properly dismount, from a stopped position, lift one leg up and set your foot back down on the ground (STEPPING BACK). Then step off completely as described in the following diagram.

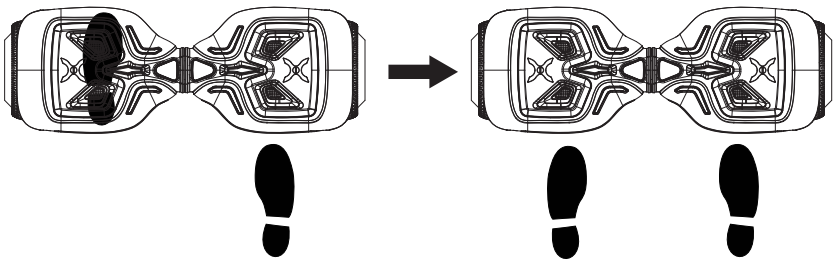

## WARNING

Make sure to lift your leg completely off the foot mat to clear the device when stepping back to dismount. Failure to do so may send the i-100 into a tailspin.

### WEIGHT AND SPEED LIMITATIONS

Speed and weight limits are set for your own safety. Please do not exceed the limits listed here in the manual.

- Maximum Weight: 220 lbs
- Minimum Weight: 44 lbs
- Maximum Speed: Up to 7 mph

## **WARNING**

Overweight exertion on the device may increase possibility of injury or product damage.

## **NOTES:**

To prevent injury, when max speed is reached, the i-100 will beep to alert the user and tilt the rider slowly back.

### **OPERATING RANGE**

The i-100 can travel a distance up to 10 miles on a fully charged battery in ideal conditions. The following are some of the major factors that will affect the operating range of your device.

- **Terrain:** Riding distance is highest when riding on a smooth, flat surface. Riding uphill and/or on rough terrain will reduce distance significantly.
- **Weight:** A lighter user will have further range than a heavier user.
- **Ambient temperature:** Please ride and store the device under recommended temperatures, which will increase driving distance; battery life, and overall performance of your device.
- **Speed and Riding Style:** Maintaining a moderate and consistent speed while riding produces maximum distance. Traveling at high speeds for extended periods, frequent starts and stops, idling and frequent acceleration or deceleration will decrease overall distance.

## **BALANCE & CALIBRATION**

**If your i-100 is unbalanced, vibrating, or not turning properly, you can follow the below steps to calibrate it.**

- First, place the i-100 on a flat, horizontal surface such as the floor or a table. The foot mats should be even with each other and not tilted forward or backward. Make sure the charger is not plugged in and the board is turned off.
- Press and hold the ON/OFF button for a total of 15 seconds. The scooter will turn on, lighting the battery indicator on the board.
- Turn the board off and then turn the board back on. Press the power button twice. Calibration will now be completed.

# SAFETY ALERTS

While riding your i-100, if there is a system error or illegal operation performed the device will prompt the user in a variety of ways.

You will notice the Running Indicator Light will turn RED and you will hear a beep sound alerting you to take precaution and cease operation, which may make the device stop suddenly.

The following are common occurrences where you will hear the Safety Alerts. These notices should not be ignored, but appropriate action should be taken to correct any illegal operation, failure or errors.

- Unsafe riding surfaces (uneven, too steep, unsafe, etc.)
- When you step on the device, if the platform is tilted more than 10 degrees forward or backward.
- Battery voltage is too low.
- The device is still charging.
- During operation, the platform self initiates to tilt due to excess speed.
- Overheating, or motor temperature is too high.
- The device has been rocking back and forth over 30 seconds.
- If the system enters protection mode, the alarm indicator will light up and the board will vibrate. This typically occurs when the battery is about to run out of power and stop abruptly.
- **If the platform is tilted forward or backward more than 10 degrees, your i-100 will power off and stop suddenly, possibly causing the rider to lose balance or fall off.**
- If any or both tires are blocked, the device will stop after 2 seconds.
- When the battery level has depleted below protection mode, the device engine will power off and stop after 15 seconds.
- While sustaining a high discharge current during use (such as

driving up a steep slope for a long period of time), the device engine will power off and stop after 15 seconds.

 **WARNING**

When the i-100 turns off during a Safety Alert, all operation systems will halt. Do not continue attempting to ride the i-100 when the system initiates a stop. Turn your i-100 off and back on to unlock it from a Safety Lock.

# CHARGING YOUR i-100

## CHARGING THE DEVICE

- Ensure that the charging port is clean and dry.
- Make sure that there is no dust, debris or dirt inside the port.
- Plug the charger into a grounded wall outlet. The charging indicator light ON THE CHARGER will be green.
- Connect the cable with the power supply (100-240V; 50/60 Hz).
- Align and connect the 3-pin charging cable into the charging port of the i-100. DO NOT FORCE OR BEND THE CHARGING CABLE INTO THE CHARGING PORT, AS IT MAY CAUSE THE PRONGS TO BEND OR BREAK.
- Once attached to the board, the charging indicator light ON THE CHARGER should change to RED, indicating that your device is now being charged.
- When the RED indicator light on your charger turns to GREEN, then your device is fully charged.
- A full charge may take up to 5 hours. While charging, you will see a yellow flashing light on the scooter, which also indicates charging. Do not charge for more than 6 hours.
- After fully charging your i-100, unplug the charger from your device and from the power outlet.

## BATTERY CARE / MAINTENANCE

### BATTERY SPECIFICATIONS

Battery Type: Rechargeable lithium-ion battery

Charge Time: Up to 5 hours

Voltage: 25.2 V

Initial Capacity: 4 .0Ah

### BATTERY MAINTENANCE

The lithium-ion battery is built into the device. Do not disassemble the device to remove the battery or attempt to separate it from the device.

- When charging the device, please use the enclosed 3-pin charging cable or otherwise ensure that the battery charging conditions are met.
- Do not connect or attach the device or the battery to a power supply plug or directly to a car's cigarette lighter.
- Do not place the device or batteries near a fire, or into direct sunlight. Heating the device and/or the battery can cause additional heating, breaking, or ignition of the battery inside the device.

- Do not continue charging the battery if it does not recharge within the specified charging time. Doing so may cause the battery to become hot, rupture, or ignite.

To preserve natural resources, please recycle or dispose of batteries properly. This product contains lithium-ion batteries. Local, state, or federal laws may prohibit disposal of lithium-ion batteries in ordinary trash. Consult your local waste authority for information regarding available recycling and/or disposal options.

 **WARNING**

Failure to follow the safety precautions listed below could lead to serious bodily injury and/or death.

- Do not attempt to modify, change, or replace your battery.
- Do not use your device if the battery begins to emit odor, overheats, or begins to leak.
- Do not touch any leaking materials or breathe fumes emitted.
- Do not allow children and animals to touch the battery.
- The battery contains dangerous substances, do not open the battery, or insert anything into the battery.
- Only use the charger provided by Hover-1.
- Do not attempt to charge the device if the battery has discharge or emits any substances. In that case, immediately distance yourself from the battery in case of fire or explosion.
- Lithium-ion batteries are considered to be hazardous materials. Please follow all local, state and federal laws in regards to recycling, handling and disposing of Lithium-ion batteries.

 **WARNING**

SEEK IMMEDIATE MEDICAL ASSISTANCE IF YOU ARE EXPOSED TO ANY SUBSTANCE THAT IS EMITTED FROM THE BATTERY.

## FCC STATEMENT

This device complies with part 15 of the FCC Rules. Operation is subject to the following two conditions: (1) This device may not cause harmful interference, and (2) this device must accept any interference received, including interference that may cause undesired operation.

Please note that changes or modifications not expressly approved by the party responsible for compliance could void the user's authority to operate the equipment.

### FCC INSTRUCTIONS FOR A CLASS B DIGITAL DEVICE OR PERIPHERAL

Note: This equipment has been tested and found to comply with the limits for a Class B digital device, pursuant to part 15 of the FCC Rules. These limits are designed to provide reasonable protection against harmful interference in a residential installation. This equipment generates, uses and can radiate radio frequency energy and, if not installed and used in accordance with the instructions, may cause harmful interference to radio communications. However, there is no guarantee that interference will not occur in a particular installation. If this equipment does cause harmful interference to radio or television reception, which can be determined by turning the equipment off and on, the user is encouraged to try to correct the interference by one or more of the following measures:

- Reorient or relocate the receiving antenna.
- Increase the separation between the equipment and receiver.
- Connect the equipment into an outlet on a circuit different from that to which the receiver is connected.
- Consult the dealer or an experienced radio/TV technician for help.

## CARE & MAINTENANCE

- Do not expose the device to liquid, moisture, or humidity to avoid damage to the product's internal circuitry.
- Do not use abrasive cleaning solvents to clean the device.
- Do not expose the device to extremely high or low temperatures as this will shorten the life of the electronic device, destroy the battery, and/or distort certain plastic parts.



- Do not dispose of the device in fire as it may explode or combust.
- Do not expose the device to contact with sharp objects as this will cause scratches and damage.
- Do not allow the device fall from high places, as doing so may damage the internal circuitry.
- Do not attempt to disassemble the device.
- Use only the charger provided by Hover-1.

 **WARNING**

Avoid using water or other liquids for cleaning. If water or other liquids enter the i-100, it will cause permanent damage to the internal components.

 **WARNING**

Users who disassemble the i-100 scooter without permission will void the warranty.

# WARRANTY

For warranty information, Please visit us at:  
[www.hover-1.com](http://www.hover-1.com)

Affix Serial Number Label Here:



@RideHover1



@RideHover1



@RideHover1



[www.Hover-1.com](http://www.Hover-1.com)