

RALLY



OPERATION MANUAL
H1-RALY

HELMETS SAVE LIVES!

Always wear a properly fitted helmet that complies with CPSC or CE safety standards when you ride your scooter.

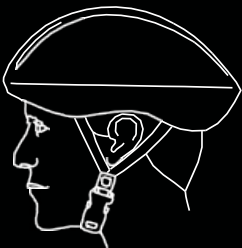

Correct Fitting:

Make sure your helmet covers your forehead.

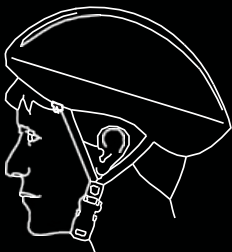

Incorrect Fitting:

Forehead is exposed and vulnerable to serious injury.

WARNING!

PLEASE READ THE USER MANUAL THOROUGHLY.

Failure to follow the basic instructions and safety precautions listed in the user manual can lead to damage to your Rally, other property damage, serious bodily injury, and even death.

Thank you for purchasing the Hover-1 Rally. Please read all instructions carefully before using and retain this manual for future use and reference.

This manual applies to the Hover-1 Rally.

- In order to avoid dangers that are caused by collisions, falls, and loss of control, please learn how to ride the Rally safely.
- You can learn operating skills by reading the product manual and watching videos.
- This manual includes operating instructions and precautions, and users must read it carefully and follow the instructions.
- All users are responsible for any consequences caused by violating warning contents or prompt operations. Hover-1 can not be held liable.

ATTENTION

1. Use only the supplied charger with this scooter.
Charger Manufacturer:
SHENZHEN HYLETON TECHNOLOGY Co.,LTD
Model: HLT-180-4201500
2. The operating temperature range of the charger is 32-104° F (0-40° C).
3. The operating temperature range of the Rally is 32-104° F (0-40° C).
4. Do not ride on icy or slippery surfaces.
5. Read the operation manual and warning labels before riding.
6. Store the Rally in a dry, ventilated environment.
7. When transporting the Rally, avoid violent crashes or impact.

LOW TEMPERATURE WARNING

Low temperature will affect the lubrication of moving parts inside the Rally, increasing internal resistance. At the same time, in low temperatures, the discharge capacity and the capacity itself of the battery will be significantly decreased.

Use caution when riding the Rally in cold temperatures (below 40 degrees F).

Doing so may increase the risk of mechanical failures of the Rally, which may lead to damage to your Rally, other property damage, serious bodily injury and even death.

SAFETY INSTRUCTIONS

- Keep the Rally away from heat sources, direct sunlight, humidity, water and any other liquids.
- Do not operate the Rally if it has been exposed to water, moisture or any other liquids to prevent against electric shock, explosion and/or injury to yourself and damage to the Rally.
- Do not use the Rally if it has been dropped or damaged in any way.
- Repairs to electrical equipment should only be performed by the manufacturer. Improper repair voids the warranty and may place the user at serious risk.
- Do not puncture or harm the exterior surface of the product in any way.
- Keep the Rally free from dust, lint, etc.
- Do not use your Rally for anything other than its intended use or purpose. Doing so may damage the Rally or lead to property damage, injury or death.
- This product is not a toy. Keep out of reach of children.
- Do not expose batteries, battery pack, or batteries installed to excessive heat, such as direct sunlight, or open flame.
- Do not allow hands, feet, hair, body parts, clothing or similar articles to come in contact with moving parts, wheels or drive-train, while the Rally is running.

- Do not operate, or allow others to operate, the Hover-1, until the user understands all instructions, warnings and safety features described in this manual.
- Check with your doctor if you have a medical condition that could affect your ability to use the Hover-1 Rally.
- Persons with head, back or neck ailments or prior surgeries to those areas of the body are not recommended to use this Hover-1 Rally.
- Do not operate if you are pregnant, have a heart condition, or have both.
- Persons with any mental or physical conditions that may make them susceptible to injury or impair their physical or mental capabilities to recognize, understand and perform all of the safety instructions and to be able to assume the hazards inherent in unit use, should not use the Hover-1 Rally.



NOTES:

In this manual, the above symbol with the word "NOTES" indicates instructions or relevant facts the user should remember prior to using the Rally.



CAUTION!

In this manual, the above symbol with the word "CAUTION" indicates a hazardous situation which, if not avoided, can cause minor or moderate injury.



WARNING!

In this manual, the above symbol with the word "WARNING" indicates a hazardous situation which, if not avoided, can cause death or serious injury.

SERIAL NUMBER

Please keep the serial number on file for warranty claims as well as proof of purchase.



WARNING!

WARNING: Prolonged Exposure to UV Rays, Rain and the Elements
May Damage the Enclosure Materials.
Store Indoors When Not in Use.

INTRODUCTION

The Rally is a personal transporter. Our technology and production processes are developed with strict testing for each Rally. Operating the Rally without following the contents of this manual may lead to damage to your Rally, or bodily injury.

This manual is designed to give you the information you need for the safe operation and maintenance of your new Rally. Please read it thoroughly before riding your Rally.

PACKAGE CONTENTS

- Hover-1 Electric Folding Scooter
- Charger
- Charging Cable
- Operation Manual

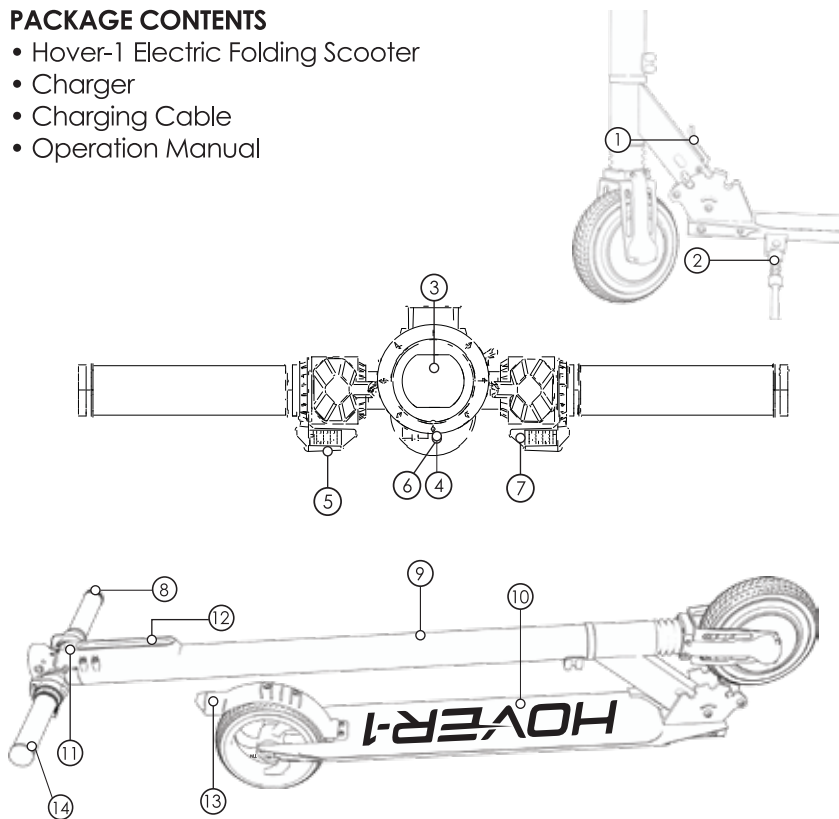

FEATURES/PARTS

- | | |
|--------------------------|----------------------|
| 1. Release Lever | 8. Handlebars(L) |
| 2. Kickstand | 9. Aluminum Frame |
| 3. LCD Display | 10. Foot Pad |
| 4. Power/Function Button | 11. LED Power Button |
| 5. Electric Brake | 12. LED Light |
| 6. Charging Port | 13. Mechanical Brake |
| 7. Throttle | 14. Handlebars(R) |

WARNING

Any Rally that does not work properly can cause you to lose control and fall. Inspect the entire device thoroughly before every ride, and do not ride it until any problems have been corrected.

SPECIFICATIONS

Model:	H1-RALY
Net Weight:	21.8 lbs (9.9 kg)
Max Supported Weight:	264 lbs (120 kg)
Min Supported Weight:	44 lbs (20 kg)
Max Speed:	Up to 12 mph (19.3 km/h)
Max Distance Range:	Up to 7 miles (11.27 km)
Battery Type:	Lithium-ion
Motor Power:	320W Brushless
Battery Voltage:	36 V
Battery Capacity:	4.0 Ah
Power Requirement:	AC 100-240V, 50/60 Hz
Folding Size:	44.09 in x 16.54 in x 11.02 in (112cm x 42 cm x 28 cm)
Open Size:	37.96 in x 16.54 in x 42.8 in (96 cm x 42 cm x 109 cm)
Tire Type:	Non-Pneumatic Solid Tires
Tire Size :	6.5 Inches (16.51 cm)
Brake Type:	Electronic & Mechanical Brakes

PREPARING YOUR RALLY

PLEASE READ THE FOLLOWING INSTRUCTIONS CAREFULLY

ATTACHING THE HANDLEBARS

Attach the handle bars by placing them into the appropriate sockets and twisting them in the correct direction.



NOTE: If the handlebars do not attach flush to the frame, you may need to shift the location of your throttle and brake assembly appropriately.

Tighten or loosen the throttle and brake assembly with the included hex key and make sure they are NOT touching or blocking your handlebars.

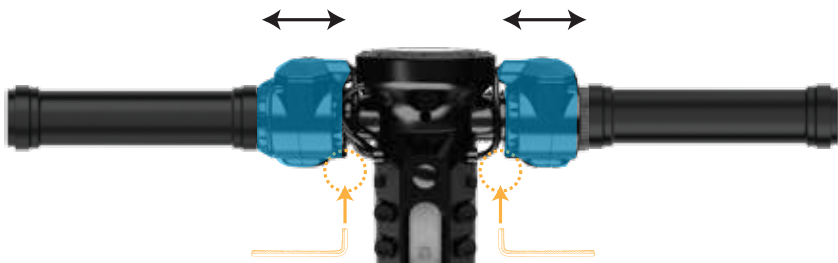

FOLDING & UNFOLDING YOUR RALLY.

Pull and hold the release lever, near the front of the foot pad, and lift the handlebars up to unfold or pull them down to fold. You will hear a click sound in both directions, this means it's now locked in place.

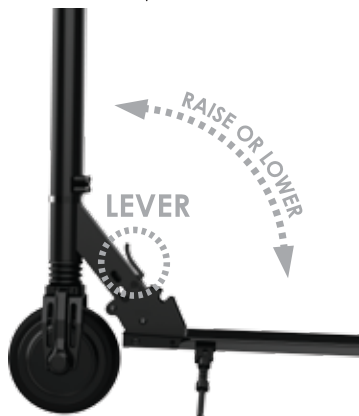

PULL & HOLD THE RELEASE LEVER TO UNLOCK

CONTROLS AND DISPLAY

LCD DISPLAY

Familiarize yourself with the LCD display of Rally. If the readout of the LCD display of your Rally is faded and unclear, you may need to recharge your Rally.

SPEED INDICATOR

Displays your current speed in MPH.

SPEED LEVEL INDICATOR

Displays your current speed level.

BATTERY LIFE INDICATOR

Displays your remaining battery life.

INFORMATION PANEL

Displays total mileage, current trip distance, voltage, and current trip time.

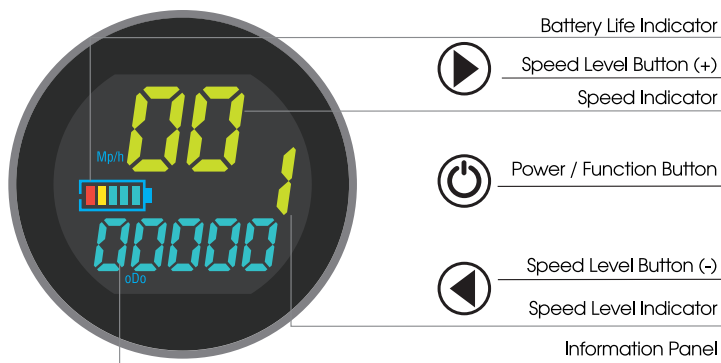

SPEED LEVEL BUTTON (+)

Press to increase top speed and acceleration.

1 – Low, 2 – Medium, 3 – High

POWER / FUNCTION BUTTON

Power ON Scooter - Press and hold for 3 seconds.

Power OFF Scooter - Press and hold for 3 seconds.

Cycle through total mileage, current trip distance, voltage, and current trip time.

SPEED LEVEL BUTTON (-)

Press to decrease top speed and acceleration.

1 – Low, 2 – Medium, 3 – High

BEFORE RIDING

WARNING

Any Rally that does not work properly can cause you to lose control and fall. Do not ride a Rally with a part that is damaged; replace the damaged part before riding.

It is important that you fully understand all elements of your Rally. If these elements are not used correctly, you will not have full control of your Rally. Before you ride, learn the functions of the various mechanisms on your scooter.

Practice using these elements of your Rally at slower speeds in a flat, open area before taking the Rally out in public areas.

PRE-RIDE CHECKLIST

Ensure that your Rally is in proper working order each and every time you ride. If a part of the scooter does not function correctly, please contact our Customer Support Center.

- Ensure the battery is fully charged before riding your scooter.
- If the Rally is not to be used for an extended period of time, you may need to recharge the battery every 2 months to maintain the battery life.
- Please wear all appropriate safety and protective gear as previously mentioned in the User Manual before operating your Rally.
- Make sure to wear comfortable clothes and flat closed-toe shoes when operating your Rally.
- Please carefully read the Operation Manual, which will assist in explaining the basic working principles and provide tips on how to best enjoy your experience.

SAFETY PRECAUTIONS

The first rule in safe riding is to use common sense.

Different localities and countries have different laws governing riding

on public roads, and you should check with local officials to ensure you are complying with these laws.

Hover-1 is not liable for tickets or violations given to riders who do not follow local laws and regulations.

- For your safety, always wear a helmet that meets CPSC or CE safety standards. In the event of an accident, a helmet can protect you from serious injury and in some cases, even death.
- Obey all local traffic laws. Obey red and green lights, one-way streets, stop signs, pedestrian crosswalks, etc.
- Ride with the traffic, not against it.
- Ride defensively; expect the unexpected.
- Give pedestrians the right-of-way.
- Do not ride too close to pedestrians and alert them if you intend to pass them from behind.
- Slow down at all street intersections and look to the left and right before crossing.

Your Rally is not equipped with reflectors. It is not recommended that you ride in conditions of low visibility.

If you are riding your scooter in low-visibility conditions, ensure your LED light is turned on, and that you are wearing bright, reflective clothing.

WARNING

When you ride in low-visibility conditions such as fog, dusk, or night, you might be difficult to see, which could lead to a collision. To increase your level of safety, be sure wear bright, reflective clothing when riding in poor lighting conditions.

Think about safety when you ride. You can prevent many accidents if you think about safety. Below is a helpful checklist for riders.

SAFETY CHECKLIST

- Do not ride above your skill level. Ensure you have had enough practice with all functions and features of your Rally.
- Do not ride too fast – with increased speed comes increased risk. If you are moving at a higher speed, small bumps can turn into large impacts, leading to a higher risk of injury if an accident occurs.
- Do not ride with pets.
- Before stepping on your Rally, make sure it is placed flat on level ground and the power is on.
- Do not try to open or modify your Rally. Doing so, voids the manufacturer warranty and may cause your Rally to fail, resulting in injury or death.
- Do not use the Rally in a manner that would put people or property in danger.
- If you and your friend(s) are riding Rally scooters together, be sure to keep a safe distance between each other to prevent collisions, property damage, serious injuries or even death.
- Be sure to keep your feet on the scooter at all times. Moving your feet off your scooter while driving is dangerous and may cause the scooter to stop or veer sideways.
- Do not operate the Rally while under the influence of drugs and/or alcohol.
- Do not operate the Rally when you are restless or sleepy.
- Use your best judgment to keep yourself out of dangerous situations with your Rally.
- Do not ride your Rally off of curbs, ramps, or attempt to operate in a skate park, empty pool, or in any way similar to a skateboard. Misuse of your Rally, voids the manufacturer warranty and may lead to injury or damage.
- Do not abuse your Rally, doing so can damage your unit and cause failure to the operating system which may lead to injury. Physical abuse, including dropping your Rally, voids the manufacturer warranty.
- Do not operate in or near puddles of water, mud, sand, stones, gravel, debris or near rough and rugged terrain.

- The Rally can be used on paved surfaces that are flat and even. If you encounter uneven pavement, please lift your Rally over and past the obstruction.
- Do not ride in inclement weather: snow, rain, hail, sleet, on icy roads or in extreme heat or cold.
- Bend your knees when riding on bumpy or uneven pavement to absorb the shock and vibration and help you keep your balance.
- If you are unsure if you can safely ride on a specific terrain, step off and carry your Rally. ALWAYS BE ON THE SIDE OF CAUTION.
- Do not attempt to ride over bumps or objects greater than ½ in. even when prepared and bending your knees.
- PAY ATTENTION - look at where you are riding and be conscious of the road conditions, people, places, property and objects around you.
- Do not operate the Rally in crowded areas.
- Operate your Rally with extreme caution when indoors, especially around people, property, and narrow spaces.
- Do not operate the Rally while talking, texting, or looking at your phone.
- Do not ride your Rally where it is not permitted.
- Do not ride your Rally near motor vehicles or on public roads.
- Do not travel up or down steep hills.
- The Rally is intended for use by a single individual, DO NOT attempt to operate the Rally with two or more people.
- Do not carry anything while riding the Rally.
- Individuals with lack of balance should not attempt to operate the Rally.
- Pregnant women should not operate the Rally.
- Young children and the elderly should not operate the Rally.

- At higher speeds, always take into consideration longer stopping distances.
- Do not attempt to jump on or off your Rally.
- Do not attempt any stunts or tricks with your Rally.
- Do not ride the Rally in dark or poorly lit areas.
- Do not ride the Rally near or over potholes, cracks or uneven pavement or surfaces.
- Do not operate your Rally off-road.
- Do not turn sharply, especially at high speeds.
- Do not exceed the maximum or minimum weight limits.
- Avoid driving the Rally in unsafe places, including near areas with flammable gas, steam, liquid, dust, fiber, which could cause fire and explosion accidents.
- Do not operate near swimming pools or other bodies of water.

 **WARNING:**

To reduce the risk of injury, adult supervision is required. Never use in roadways, near motor vehicles, on or near steep inclines or steps, swimming pools or other bodies of water; always wear shoes, and never allow more than one rider.

RIDING YOUR RALLY

FAILURE TO FOLLOW ANY OF THE FOLLOWING SAFETY PRECAUTIONS CAN AND MAY LEAD TO DAMAGE TO YOUR RALLY, VOID YOUR MANUFACTURER WARRANTY, LEAD TO PROPERTY DAMAGE, CAUSE SERIOUS BODILY INJURY, AND CAN LEAD TO DEATH.

OPERATING YOUR RALLY

Make sure the Rally is fully charged before the first initial use. Before turning on your Rally, ride it like a normal kick scooter to get comfortable with the Rally before using it with the motor.

When comfortable riding the scooter, power it on. For the motor to activate, you must first start riding the scooter and then push the throttle down.

To slow down the scooter, push the electric brake down. This will stop the motor and slow you down. Also press the mechanical brake with your foot to manually slow down the scooter.

The Rally is equipped with a built-in 320 Watt Brushless Motor which allows you to accelerate (up to 12 mph) and decelerate.

To turn, use the handlebar to turn in the direction you wish to turn.

The Rally can be operated manually if you do not wish to use the motor.

As you get comfortable on the Rally, you will notice it becomes easier to maneuver. Remember at higher speeds, it is necessary to shift your weight to overcome the centrifugal force.

Bend your knees if you encounter bumps or uneven surfaces, then dismount and carry your Rally to a safe operating surface.

WARNING

Do not turn sharply or at high speeds to avoid danger. Do not turn or ride quickly along slopes, as it may cause injury.

WEIGHT AND SPEED LIMITATIONS

Speed and weight limits are set for your own safety. Please do not exceed the limits listed here in the manual.

- Maximum Weight: 264 lbs
- Minimum Weight: 44 lbs
- Maximum Speed: Up to 12 mph

WARNING

Overweight exertion on the Rally may increase possibility of injury or product damage.

OPERATING RANGE

The Rally can travel a distance up to 7 miles on a fully charged battery in ideal conditions. The following are some of the major factors that will affect the operating range of your Rally.

- Terrain: Riding distance is highest when riding on a smooth, flat surface. Riding uphill and/or on rough terrain will reduce distance significantly.
- Weight: A lighter user will have further range than a heavier user.
- Ambient temperature: Please ride and store the Rally under recommended temperatures, which will increase driving distance; battery life, and overall performance of your Rally.
- Speed and Riding Style: Maintaining a moderate and consistent speed while riding produces maximum distance. Traveling at high speeds for extended periods, frequent starts and stops, idling and frequent acceleration or deceleration will decrease overall distance.

SAFETY ALERTS

While riding your Rally, if there is a system error or an illegal operation occurred, the Rally will prompt the user in a variety of ways.

The following are common occurrences where you will see Safety Alerts. These notices should not be ignored, but appropriate action should be taken to correct any illegal operation, failure or errors.

- Prohibited riding surfaces (uneven, too steep, unsafe, etc.)
- Battery voltage is too low.
- The Rally is still charging.
- Overheating, or motor temperature is too high.
- If the system enters protection mode, the alarm indicator will light up. This typically occurs when the battery is about to run out of power.

- If any or both tires are blocked, the Rally will stop after 2 seconds.
- When the battery level has depleted below protection mode, the Rally motor will power off after 15 seconds.

While sustaining a high discharge current during use (such as riding up a steep slope for a long period of time), the Rally motor will power off after 15 seconds.

CHARGING YOUR RALLY

CHARGING THE RALLY

- Ensure that the charging port is clean and dry.
- Make sure that there is no dust, debris or dirt inside the port.
- Plug the charger into a grounded wall outlet.
- Connect the cable with the power supply (100V ~ 240V; 50/60 Hz).
- Align and connect the 1-pin charging cable into the charging port of the Rally. **DO NOT FORCE OR BEND THE CHARGING CABLE INTO THE CHARGING PORT, AS IT MAY CAUSE THE PRONGS TO BEND OR BREAK.**
- The charging indicator light should change to RED, indicating that your Rally is now being charged.
- When the RED indicator light on your charger turns to GREEN, then your Rally is fully charged.
- A full charge may take up to 4 hours.
- After fully charging your Rally, unplug the charger from your Rally and from the power outlet.

BATTERY CARE / MAINTENANCE

BATTERY SPECIFICATIONS

Battery Type: Rechargeable lithium-ion battery

Charge Time: Up to 4 hours

Voltage: 36V

Initial Capacity: 4.0 Ah

Working Temperature: 32°F - 104°F

Charging Temperature: 32°F - 104°F

Storage Time: 1 year

Storage Temperature: -4°F - 77°F

Storage Humidity: 5% - 95%

BATTERY MAINTENANCE

The lithium-ion battery is built into the Rally. Do not disassemble the Rally to remove the battery or attempt to separate it from the Rally.

- When charging the Rally, please use the enclosed 1-pin charging cable or otherwise ensure that the battery charging conditions are met.
- Do not connect or attach the Rally or the battery to a power supply plug or directly to a car's cigarette lighter.
- Do not place the Rally or batteries near a fire, or into direct sunlight. Heating the Rally and/or the battery can cause additional heating, breaking, or ignition of the battery inside the Rally.
- Do not continue charging the battery if it does not recharge within the specified charging time. Doing so may cause the battery to become hot, rupture, or ignite.

To preserve natural resources, please recycle or dispose of batteries properly. This product contains lithium-ion batteries. Local, state, or federal laws may prohibit disposal of lithium-ion batteries in ordinary trash. Consult your local waste authority for information regarding available recycling and/or disposal options.

 **WARNING**

Failure to follow the safety precautions listed below could lead to serious bodily injury and/or death.

- Do not attempt to modify, change, or replace your battery.
- Do not use your Rally if the battery begins to emit odor, overheats, or begins to leak.
- Do not touch any leaking materials or breathe fumes emitted.
- Do not allow children and animals to touch the battery.
- The battery contains dangerous substances, do not open the battery, or insert anything into the battery.
- Please only use the charger provided by Hover-1.
- Do not attempt to charge the Rally if the battery has discharge or emits any substances. In that case, immediately distance yourself from the battery in case of fire or explosion.

- Lithium-ion batteries are considered to be hazardous materials. Please follow all local, state and federal laws in regards to recycling, handling and disposing of Lithium-ion batteries.

WARNING

SEEK IMMEDIATE MEDICAL ASSISTANCE IF YOU ARE EXPOSED TO ANY SUBSTANCE THAT IS EMITTED FROM THE BATTERY.

FCC STATEMENT

This device complies with part 15 of the FCC Rules. Operation is subject to the following two conditions: (1) This device may not cause harmful interference, and (2) this device must accept any interference received, including interference that may cause undesired operation.

Please note that changes or modifications not expressly approved by the party responsible for compliance could void the user's authority to operate the equipment.

FCC INSTRUCTIONS FOR A CLASS B DIGITAL DEVICE OR PERIPHERAL

Note: This equipment has been tested and found to comply with the limits for a Class B digital device, pursuant to part 15 of the FCC Rules. These limits are designed to provide reasonable protection against harmful interference in a residential installation. This equipment generates, uses and can radiate radio frequency energy and, if not installed and used in accordance with the instructions, may cause harmful interference to radio communications. However, there is no guarantee that interference will not occur in a particular installation. If this equipment does cause harmful interference to radio or television reception, which can be determined by turning the equipment off and on, the user is encouraged to try to correct the interference by one or more of the following measures:

- Reorient or relocate the receiving antenna.
- Increase the separation between the equipment and receiver.
- Connect the equipment into an outlet on a circuit different from that to which the receiver is connected.
- Consult the dealer or an experienced radio/TV technician for help.

CARE & MAINTENANCE

- Do not expose the Rally to liquid, moisture, or humidity to avoid damage to the product's internal circuitry.
- Do not use abrasive cleaning solvents to clean the Rally.
- Do not expose the Rally to extremely high or low temperatures as this will shorten the life of the Rally, destroy the battery, and/or distort certain plastic parts.
- Do not dispose of the Rally in fire as it may explode or combust.
- Do not expose the Rally to contact with sharp objects as this will cause scratches and damage.
- Do not let the Rally fall from high places, as doing so may damage the internal circuitry.
- Do not attempt to disassemble the Rally.
- Use only the charger provided by Hover-1.

WARNING

Avoid using water or other liquids for cleaning. If water or other liquids enter the Rally, it will cause permanent damage to the internal components.

WARNING

Users who disassemble the Rally scooter without permission will void the warranty.

WARRANTY

For warranty information, Please visit us at:
www.hover-1.com

Manufacturer: DGL Group, Ltd.
195 Raritan Center Parkway Edison, NJ 08837

Affix Serial Number Label Here:



@RideHover1



@RideHover1



@RideHover1



www.Hover-1.com