



BLUE SKY

OUTDOOR LIVING

OWNER'S MANUAL
**FOOT OPERATED
LOG SPLITTER**

LSF-001

Blue Sky can provide elevated ambience, quality and safety to your outdoor living space. Our products are designed to create a practical space to bring people together. Whether you're using Blue Sky products to roast s'mores in your backyard, enjoy a beach bonfire, assist at your tailgate or accompany you on a camping trip, you can rely on their durability and performance. Thank you for your purchase of this Blue Sky log splitter.

CONNECT WITH US

www.blueskyoutdoorliving.com



@blueskyoutdoorliving

Fill in the following information and retain this manual for future reference:

MODEL(S):

DATE OF PURCHASE:

PLACE OF PURCHASE:

RECEIPT NO:



LSF-001

LSF-001

Foot Operated Log Splitter

10.6" W x 32.7" L x 9.1" H

27 cm W x 83 cm L x 23 cm H

CUTTING CAPACITY:

10" (25.4 cm) Dia

18" (45.7 cm) L

FOR YOUR SAFETY

PLEASE READ AND UNDERSTAND ALL SAFETY RULES BEFORE ASSEMBLING AND USING THIS LOG SPLITTER. SAVE THESE INSTRUCTIONS FOR FUTURE USE.

RULES FOR SAFE OPERATION

- Use ANSI approved safety goggles at all times.
- Keep a safe distance from unit when unclipping. Keep face, head, arms and hands away from the bar while operating the unit.
- Keep children and bystanders a safe distance away from unit while operating.
- Maintain good balance while operating unit. If needed, hold onto something stable while stepping down on pedal.
- Use this log splitter on the floor in a horizontal position. Improper use will create risk of injury.

HELPFUL HINTS

- To keep the unit clean and operating smoothly, keep moving parts lubricated with an anti-rust machine oil.
- Wet or non-seasoned wood is more difficult to split than dry wood because the fibres stick together. Reversing the block and splitting from the other end may help if you cannot pull the wood apart.
- Large or multiple knots in a log make splitting more difficult. Usually if the log is rotated so that the knots are vertical to the blade, the wood will split more easily and less stress is placed on the log splitter. This will reduce wear and tear or the possibility of damaging the log splitter.
- Damage from over stress or abuse may void the warranty on your log splitter. This splitter is not designed to replace heavy duty hydraulically powered equipment.

PARTS LIST

UNPACK PARTS, MAKING SURE ALL PIECES ARE PRESENT BEFORE ATTEMPTING TO ASSEMBLE.

REF	QTY	DESCRIPTION
A	1	Body
B	1	Foot

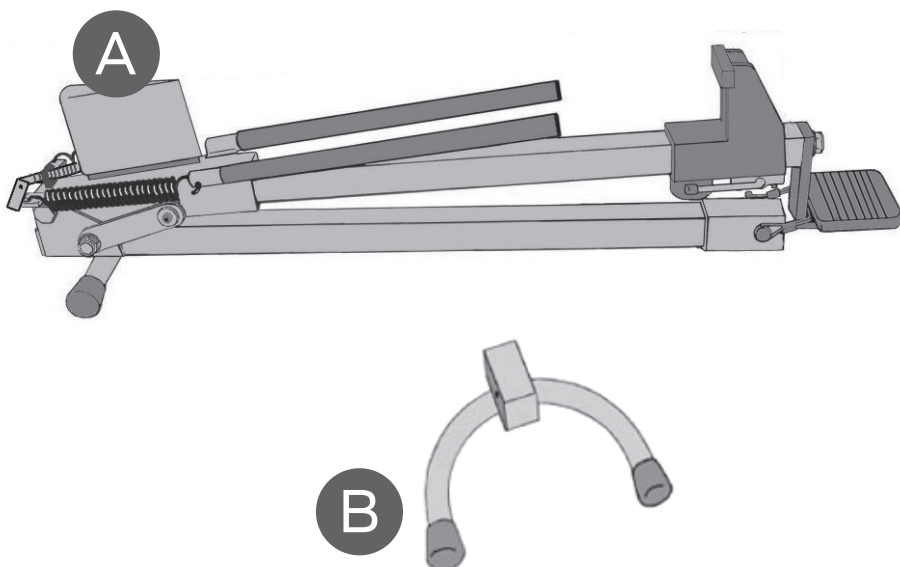

ASSEMBLY

GET TO KNOW YOUR LOG SPLITTER

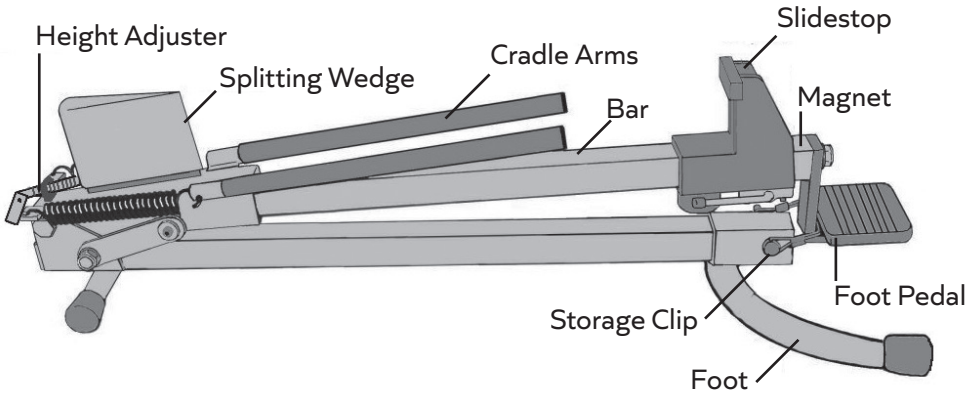

STEP 1

Apply downward pressure on the bar. Unclip and remove the storage clip, then slowly release pressure. The bar will rise 2" (5.08 cm).

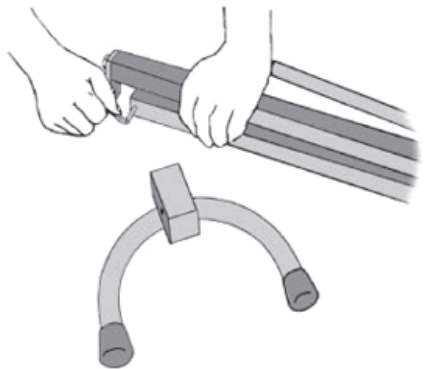

STEP 2

Slide the foot onto the log splitter body.

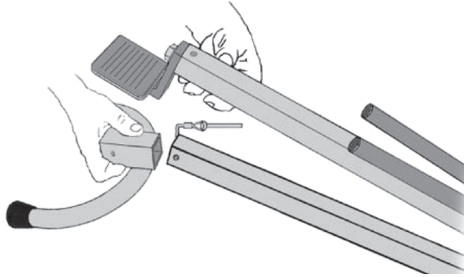

STEP 3

Press down on the foot pedal and re-clip the storage clip.

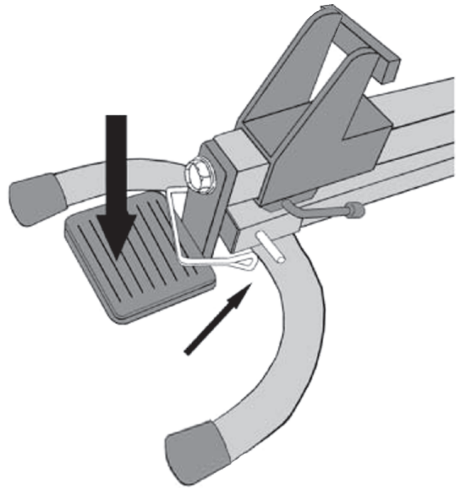

STEP 4

Turn the height adjuster two to three times counter clockwise.

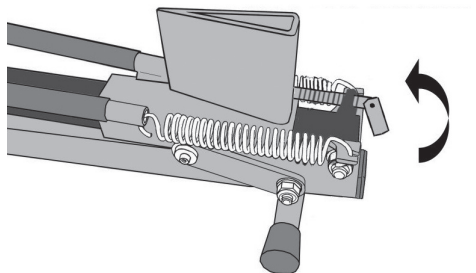

STEP 5

Undo the storage clip, then re-clip after the bar is up.

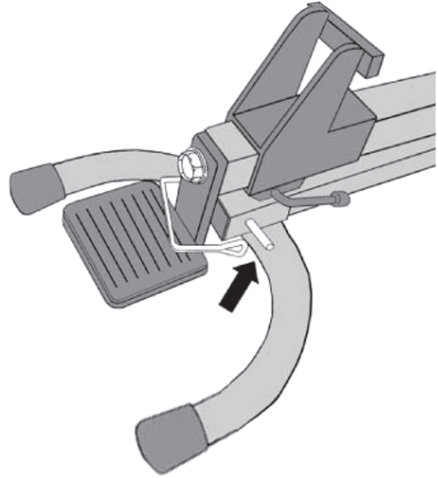

STEP 6

Adjust foot pedal height 12"-13" (30 cm-33 cm). The log splitter is now ready for use.

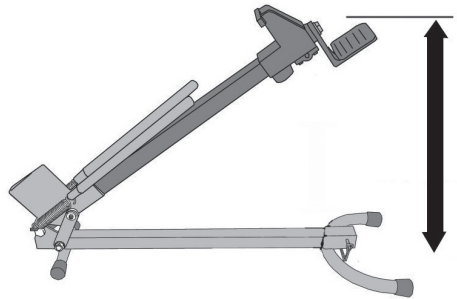

OPERATION

STEP 1

ATTENTION: Place the log splitter on a mat to protect flooring, if necessary.

Insert a log, then push the slidestop until the log is secure. The magnet will hold the slidestop in place.

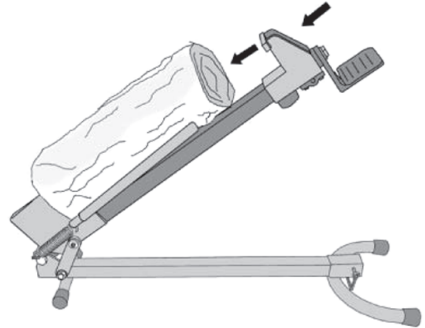

STEP 2

Step down on the foot pedal.

You may need to repeat this step three or four times to split an average log.

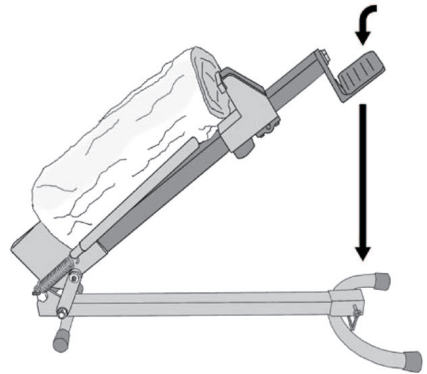

STEP 3

NOTE: Place your foot down on the base of the log splitter to secure it.

Lift up on the slidestop lever and pull the slidestop back.

Pull the log out sideways to remove.

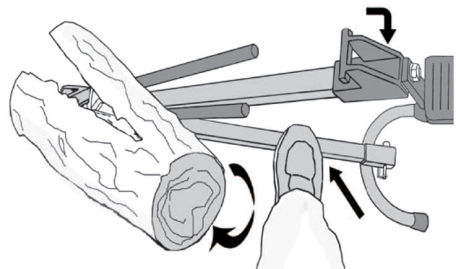

ONE YEAR LIMITED WARRANTY

This product is warranted to be free from defects in materials and workmanship for a period of one (1) year from the date of original purchase. This guarantee is for home owner use only and is not valid if the unit is used for commercial or rental use. The guarantee may not be honored if, in the opinion of the retailer, the unit has been misused, dropped, taken apart and/or has been the subject of unusual wear and tear, and/or if repairs have been made or attempted by those other than specified by manufacturer. Disassembling the unit will also void the warranty.

WARRANTY CLAIM PROCEDURE

If a claimable defect occurs, contact our customer service department at service@qualitycraft.com or 1-800-459-4409 (Monday–Friday, 8:00 am–4:30 pm, CST).

Before you make your claim call, please make sure you have:

1. The description of the log splitter
2. Proof of sale
3. Details regarding the defect
4. Name and address of the owner and installer

Claims must be filled out in writing and returned within six (6) months of appearance of defect. Failure to comply with this stipulation will make the warranty null and void. We reserve the right to a thirty (30) day delay following receipt of claim in which to inspect the product. We assume no responsibility for labor costs, removing/replacing a previously installed product, transportation or return of the product.



BLUE SKY

OUTDOOR LIVING

Manufactured by:

Quality Craft

Surrey, BC, Canada V3S 5N4

service@qualitycraft.com

1-800-459-4409

(Monday to Friday, 8:00 am–4:30 pm, CST)

Made in China

BKOLLSF-12/18