

SKYHAWK

FOLDABLE VIDEO GPS DRONE



DRC-447
USER MANUAL



AUTO
HOVER



ONE KEY
RETURN



1000ft
RANGE



HEADLESS
MODE



GPS
TRANSMISSION



WiFi
APP
CONTROL



FOLLOW ME
MODE



FULL
HD
1080
ARTICULATING
VIEW

APP Download QR Code



Contents

Product Profile	1
Please read this User Manual	1
Setting Up Your DRC-447	1
Setting Up the Remote Controller	2
A Quick Look at Your Device	3
Remote Controller	4
Aircraft	5
Flight Modes	5
Aircraft Status Indicator	6
Return to Home (RTH)	7
Aircraft Guard Rails Installation	8
Aircraft Power Switch	9
Aircraft Battery	9
Attaching and Detaching the Propellers	10
App Download & Installation	12
Downloading the “VTI SkyHawk” Application	12
Remote Controller And APP	13
Remote Controller & APP Functions	14
Installing the Mobile Phone Holder	15
Flight	16
Environmental Requirements	16
Pre-flight Checklist	16
Calibrating Your Aircraft (Preparing for Flight)	17
Speed Adjustment	21
Point of Interest (Surrounding Flight Mode)	21
Follow Me	22
Test Flight	22
Important Statement	23
Flight Safety Guidelines	23

PART 1: Product Profile

This section introduces functions and installation guidelines of the DRC-447 and lists the components of the aircraft and Remote Controller.

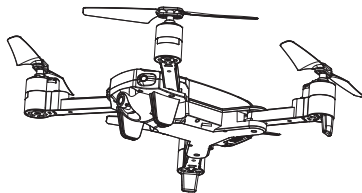

IMPORTANT NOTE: FAA REGISTRATION

Owners of a drone that weighs more than 0.55 lbs. (250 g) and less than 55 lbs. (25 kg) must register their UAS online at the FAA website, <https://www.faa.gov/uas/registration>.

After receiving the certificate of registration, a unique FAA registration number will be provided and it must be marked on the Drone by any means, such as permanent marker, label, engraving, or other means, as long as the number is readily accessible and maintained in a condition that is readable and legible upon close visual inspection.

Please read this User Manual

Thank you for purchasing the VTI SkyHawk Foldable Video GPS aircraft, item DRC-447. The included Remote Controlled aircraft is designed specifically for outdoor flying. In order to get the best possible results, please read this user's manual carefully before using. In addition, be sure to keep this manual in a safe place for future reference.

Setting Up Your DRC-447

Unfold the Aircraft

The aircraft is folded inside the package. Please unfold the aircraft before use.

1. Unfold the rear arms.
2. Unfold the front arms.

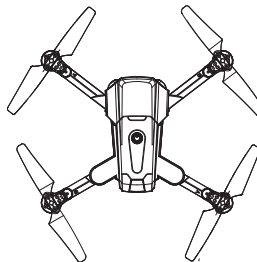
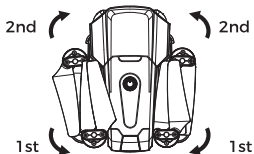

Battery Installation

Drone Battery: Please make sure the battery is fully charged before installation. Insert the charged battery into the battery case at the back of the aircraft. Make sure that you hear a clicking sound which indicates that the battery has been inserted securely.

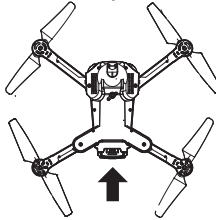

⚠ Attention: Failure to securely insert the battery can lead to your aircraft losing power mid flight and crashing.

Setting Up the Remote Controller

Inserting Batteries Into Your Remote Controller

1. Use a screwdriver to open up the battery compartment located on the rear of your remote controller.
2. Insert 3 AAA 1.5V batteries, making sure that the batteries are inserted with the correct polarity (+,-) as displayed in the battery compartment.
3. Once the batteries are inserted, place the battery compartment cover back on the battery compartment, and use a screwdriver to close it securely.

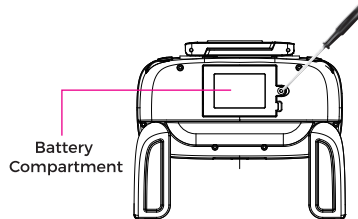

- Do not mix rechargeable and non-rechargeable batteries.
- Do not mix old and new batteries or different types of batteries.
- Remove exhausted batteries and dispose of them based on the rules of your local municipality.
- Remove the batteries from your Remote Controller if it will not be in use for an extended period of time.

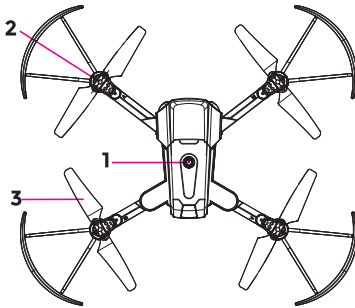
A Quick Look at Your Device**TOP VIEW**

1. Power switch
2. Coreless motor
3. Propeller

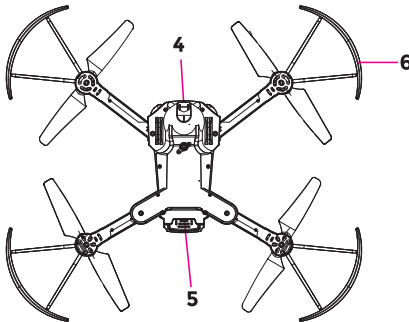
**BOTTOM VIEW**

4. Camera
5. Battery
6. Guard rails

Note: Camera shooting angles can be adjusted by hand.

Remote Controller

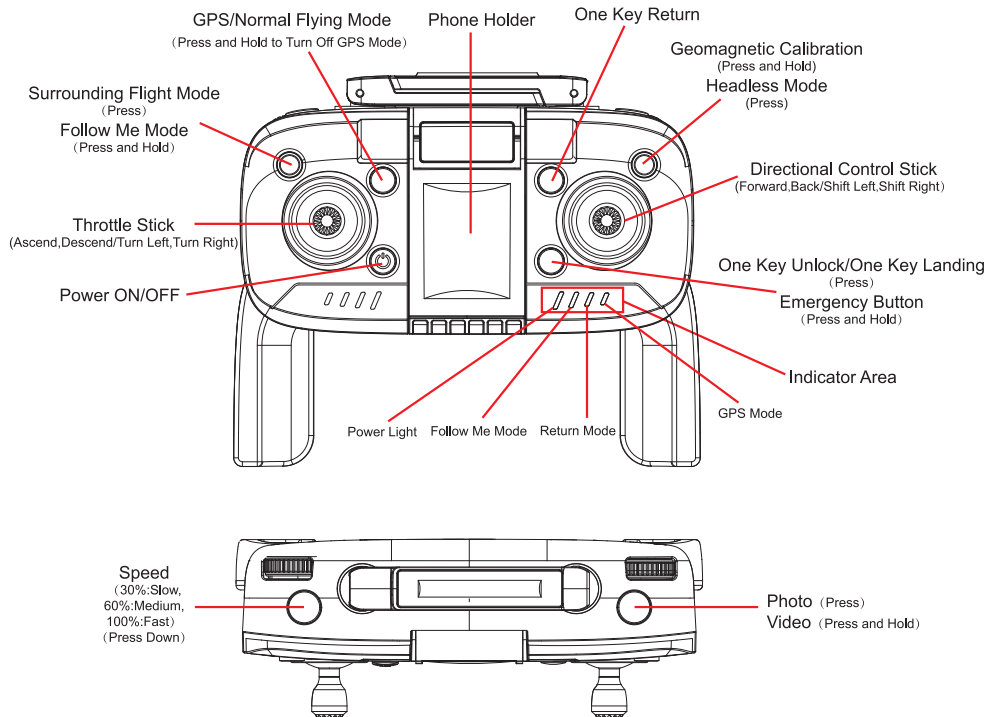

When the aircraft is turned on, it automatically goes into GPS mode.

PART 2: Aircraft

This section introduces functions and features of the DRC-447.

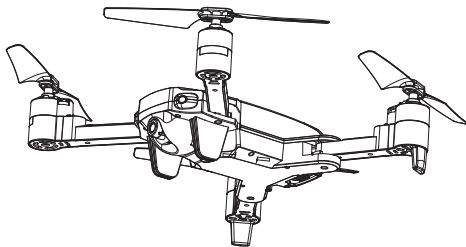

Flight Modes

Your DRC-447 has 2 flight modes.

GPS Mode: When the aircraft is turned on, it automatically goes into GPS mode.

Normal Flying Mode: Press and hold the GPS/Normal Flying Mode button to switch to Normal Flying Mode.

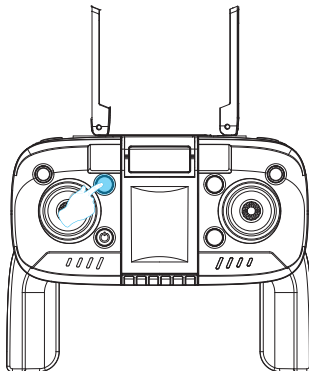

Aircraft Status Indicator

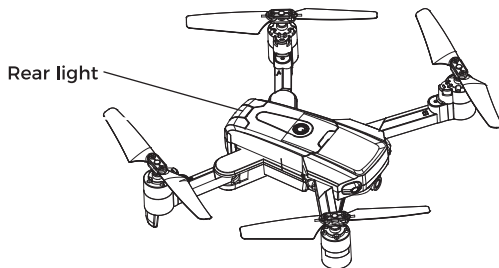

Aircraft Status Indicator

GPS MODE		
Before finding GPS Signal	FRONT LED	WHITE
	REAR LED	RED
After finding GPS signal	FRONT LED	WHITE
	REAR LED	GREEN

NORMAL MODE(NO GPS)	
FRONT LED	WHITE
REAR LED	YELLOW

Rear Light Status Under GPS Mode

No.	Indicator Status	Rear Light
1	Turn on Aircraft	Flashes Yellow
2	Aircraft and Remote Connection	Solid Red
3	Start Compass Calibration	Flashes Yellow
4	Finish Compass Calibration	Solid Red
5	Search GPS Signal	Solid Green
6	Return To Home	Solid Red
7	Return to Home with Low Battery	Flashes Red
8	Headless Mode	Flashes Red + Green
9	Lose Control	Flashes Red

Return to Home (RTH)

The Return-to-Home (RTH) function brings the aircraft back to the last recorded Home Point. There are 3 types of RTH: Smart RTH, Low Battery RTH and Failsafe RTH. This section describes these 3 scenarios in detail.

📖	GPS	Description
Home Point	 7/S	If a strong GPS signal (satellites over 7) was acquired before takeoff, the Home Point is the location from which the aircraft was launched. The aircraft's rear indicator lights will flash both red and green colors when the Home Point is recorded.



- The aircraft cannot avoid obstacles when it is flying back with the RTH function initiated.
- The aircraft cannot return to the Home Point when the GPS signal is weak or unavailable.

Smart RTH

When the GPS signal is available (more than 7 satellites is presented), use the RTH button on the Remote Controller (Pic. 1) or tap the RTH button in the “VTI SkyHawk” APP (Pic. 2) and then follow the on-screen instructions to initiate Smart RTH.

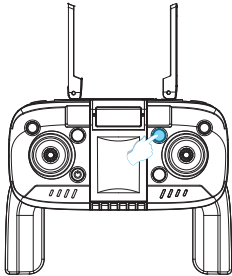

Pic. 1



Pic. 2

Low Battery RTH

When the battery level of your aircraft is low, it automatically returns directly to the take-off point. During the state of low battery, the aircraft cannot be controlled beyond 20 meters. If the aircraft is returned to within 20 meters from the take-off point, it can be controlled. If it is beyond 20 meters, the aircraft then enters into the landing protection mode in which it performs as follows – because it will not be able to fly more than 20 meters and will not be able to automatically return, it will safely land immediately when the battery is totally depleted.

 **Note:** When the aircraft is in a state of low battery, the front white light is on, and the rear red light flashes.

Failsafe RTH

If the Home Point was successfully recorded and the compass is functioning normally, Failsafe RTH will be automatically activated if the Remote Controller signal is lost for over 6 seconds. Return-to-Home can be cancelled by the pilot, allowing you to regain control when the Remote Controller signal connection is re-established.

Aircraft Guard Rails Installation

Align the guard rails with the hole in the upper position of the aircraft, and install and fasten them.

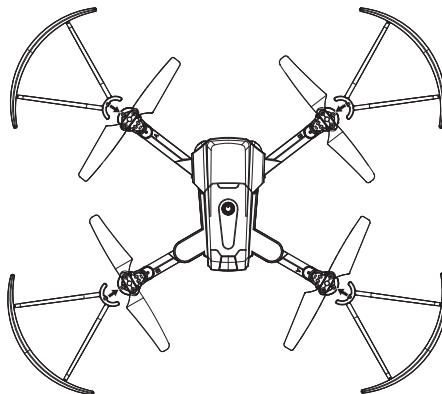

Aircraft Power Switch

Turn On the Aircraft

Once the battery is inserted securely, press and hold the power button for 3 seconds. The aircraft makes beeping sounds and the rear light flashes continuously.

Turn off the Aircraft

Press the power button, the aircraft's light goes off and the aircraft will then power off.

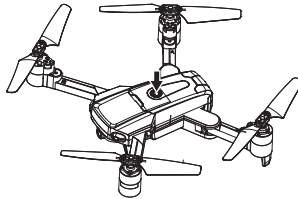

Aircraft Battery

- Made by high-energy battery cells
- Standard battery capacity is 7.4V 1500mAh

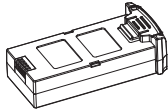

Aircraft battery



USB cable

Charging the Aircraft Battery

- The aircraft's battery needs to be fully charged before every flight.
- Please use the included USB cable in order to charge the aircraft's battery.
- The battery takes approximately 200 minutes to charge fully.

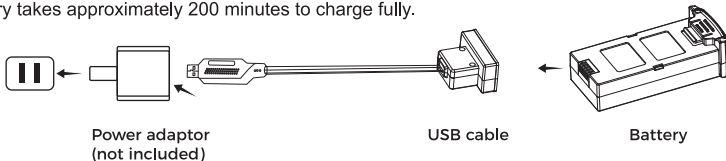

Power adaptor
(not included)

USB cable

Battery



- Do not let children play with this aircraft without adult supervision.
- Insert batteries with correct polarity.
- Rechargeable batteries are to be removed from the aircraft before being charged.
- Rechargeable batteries are only to be charged under adult supervision.
- Exhausted batteries are to be removed from the aircraft.
- The supply terminals are not to be short-circuited.
- The charging line should regularly be examined for potential hazards, such as damage to the cable, cord, plug, enclosure or any other parts. In the event of such damage, the product must not be used until such damage has been properly removed.

Attaching and Detaching the Propellers

Attach the Propellers

Install propeller A and propeller B on the corresponding motor shaft and fix each propeller's screws tightly by rotating them in a clockwise direction. (A/B markings are on the bottom of each propeller.)

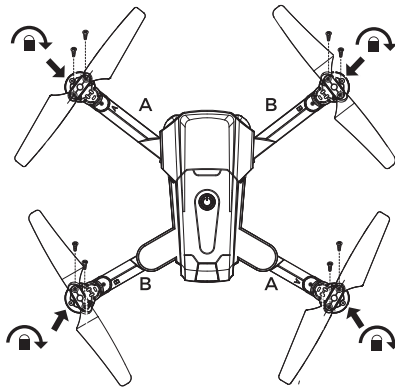

Detach the Propellers

Take out the screws by rotating them in counter-clockwise direction and then remove the propellers.

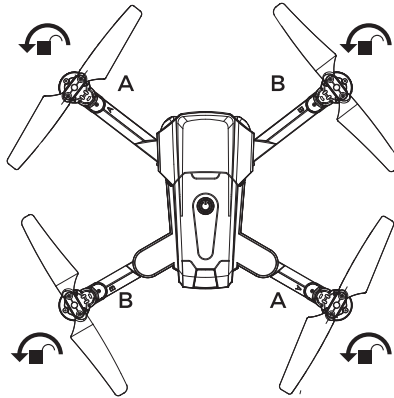

- Please make sure that the propellers are attached to the correct motors, because the aircraft will not fly normally if the wrong propellers have been attached.
- Be aware of the sharp edges of the propellers. Handle with care.
- Use only original default propellers. DO NOT mix propeller types.
- Stand clear of the motors and DO NOT touch the propellers when they are spinning.
- Check that the propellers and motors are installed correctly and are attached securely before every flight.
- Ensure that all propellers are in good condition before each flight. DO NOT use aged, chipped, or broken propellers.
- To avoid injury, STAND CLEAR of and DO NOT touch propellers or motors when they are spinning.
- ONLY use original default propellers for a better and safer flight experience.

PART 3: App Download & Installation

This section explains how to download the “VTI SkyHawk” APP and connect your aircraft with your mobile device.

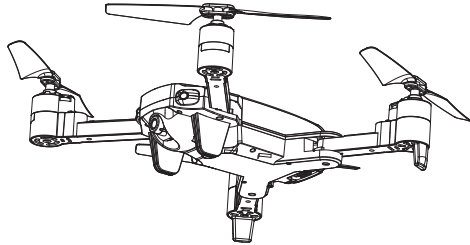

Downloading the “VTI SkyHawk” Application

Download the “VTI SkyHawk” APP

1. For Apple IOS users, please go to the Apple App Store, and search “**VTI SkyHawk**” or scan the QR code below to download the software application.
2. For Android users, please go to the Google Play Store, and search “**VTI SkyHawk**” or scan the QR code below to download the software application.



How to Link the App to the Aircraft's Camera

Power on the aircraft, then enter your phone's settings menu. Turn on WiFi, find **Sky Hawk Drone ****** on the list and connect to it. When the WiFi “” symbol appears, it means WiFi has been successfully connected. Exit the phone's settings menu and tap the “VTI SkyHawk” APP icon on your mobile device to open the APP. Select your aircraft model on the home page and tap “**GO**” to enter into the real-time image transmission interface.

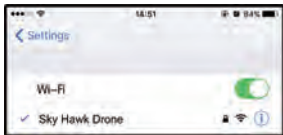

Connect WIFI



VTI SkyHawk

Tap “VTI SkyHawk” App



Click “GO”

Photo and Video Saving Feature

Video and Photos captured by your aircraft will be saved at the APP.

Photo & Video resolution:1920*1080

PART 4: Remote Controller and APP

This section describes the features of the remote controller and VTI SkyHawk app. It includes instructions on how to operate the DRC-447.

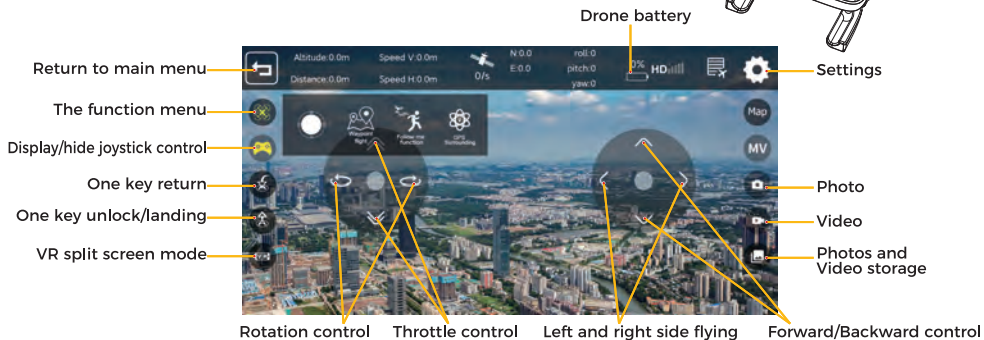
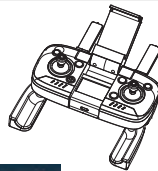

Remote Controller & APP Functions

Photo/Video

Photo: Tap the photo/video button on the remote controller and on the app to take a photo.

Video: Press and hold the photo/video button to take a video on the remote controller. Press and hold the photo/video button again to stop recording. Tap the video button on app to take video, and tap again to stop recording. All photos and videos will be saved to your phone.

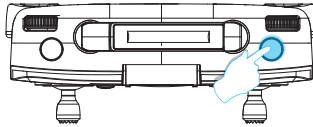

One Key Unlock/Landing

- Tap the One Key Unlock/Landing button, and the aircraft will lock. Pull up on the throttle stick, and the aircraft will fly up.
- Tap the same button to land.

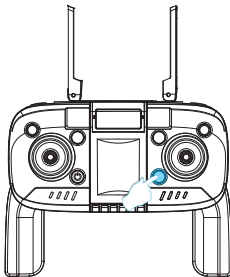

Emergency Stop

Press the button for 3 seconds to stop the flight immediately. Only do this in urgent, emergency situations as it may cause the aircraft to crash.

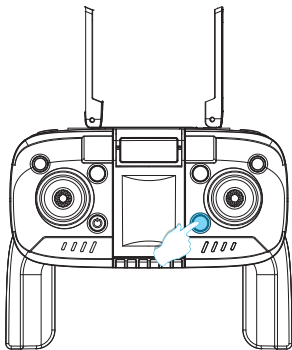

Installing the Mobile Phone Holder

1. Open the mobile phone holder (Pic. 1);
2. Adjust the mobile phone holder upward or downward according to the size of your mobile phone (Pic. 2).

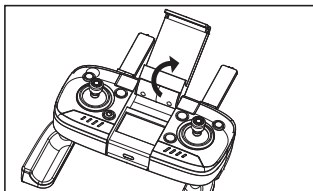

Pic. 1

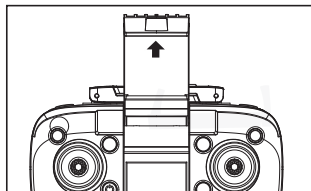

Pic. 2

PART 5: Flight

This section reviews safe flight requirements and basic aircraft operations.

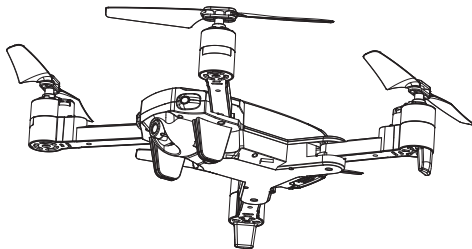

Environmental Requirements

1. Please don't fly in areas with extremely high temperatures, snow, strong wind (≥level 5), rain or fog.
2. Always choose a wide open area for every flight. Tall structures and large metal structures may affect the accuracy of the onboard compass and GPS system.
3. Never fly directly over people or animals.
4. To minimize interference, please do not fly the aircraft in locations near power lines, base stations, electrical substations and broadcasting towers.
5. Aircraft and battery performance is subject to environment factors like temperature. Be very careful when flying over 1000ft above sea level since the performance will be affected.
6. Your aircraft cannot use GPS within polar regions.

Flight Limits and GEO Zones

Abide by all laws and regulations when flying your aircraft. Flight limitations are applied by default to help users operate this product safely and legally. Flight limitations include altitude limits, distance limits and GEO Zones. Altitude limits, distance limits and GEO Zones function concurrently to manage flight safety when operating in GPS Mode.

Pre-flight Checklist

Before flight, make sure that:

1. The aircraft, Remote Controller and mobile device are full charged.
2. The propellers are installed correctly.
3. The arms and propellers are properly unfolded.
4. The camera lens is clean.

Calibrating Your Aircraft (Preparing for Flight)

Before preparing your aircraft for flight, first make sure that you have a suitable environment for flight. Avoid flying in rain or snow, or in windy conditions. Stay away from people, trees, power lines, tall buildings, airports and signal towers. Your aircraft is specifically designed for outdoor flying. Do not attempt to fly your aircraft or calibrate it indoors.

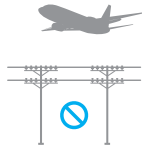

To power on your Remote Controller, press the Power ON/OFF button. You will hear a beep when it powers on. To power on your aircraft, press and hold the Power button. The LED light on the aircraft flashes rapidly. Once your aircraft and Remote Controller are powered on, follow the calibration steps below in order to prepare your aircraft for flight.

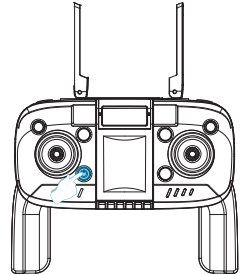
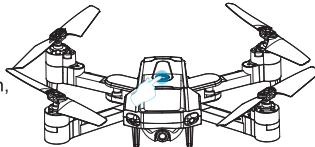

Calibrating Your Aircraft with Your Remote Controller

1. With your aircraft and Remote Controller both powered on, pull the throttle stick on the Remote Controller all the way up and then push it all the way down.
2. When you hear your Remote Controller make a beeping sound, then your aircraft is synchronized with your Remote Controller.

NOTE: Once you turn on your aircraft, it will go into GPS mode automatically.

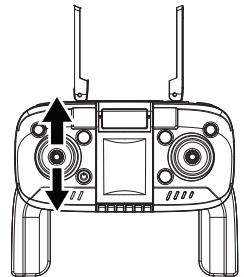

Aircraft Compass Calibration

Note: Your aircraft needs to go through the geomagnetic calibration process only when flying it for the first time from the new location. Thereafter, when flying from the same location, there is no need to go through the geomagnetic calibration process. Your aircraft can then fly under GPS mode.

When the environment is not suitable for flying, your aircraft quickly recovers a stable altitude and automatically returns to the take-off position after circling for a few seconds.

1. Press and hold the geomagnetic calibration button. (Pic 1)
2. Rotate your aircraft horizontally, spinning it in a clockwise direction continuously until the white lights on the front of your aircraft keep flashing, while the lights on the back of your aircraft solidly shine yellow, and your aircraft will emit a beep sound. (Pic 2)
3. Turn the head downwards and rotate your aircraft vertically, spinning it continuously until the white lights on the front of your aircraft and the red lights on the back of your aircraft both stop blinking and continue to shine steadily. Calibration is complete. After several seconds, once the aircraft can find a GPS signal, the front LEDs will turn solid white and the back LEDs will turn green, and your aircraft will emit a beep sound. (Pic 3)

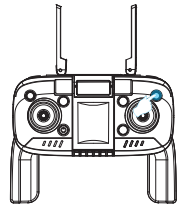

Pic 1

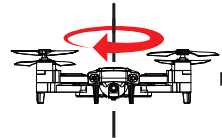

Pic 2



Pic 3

Exiting GPS Mode

If you would like to exit GPS Flying Mode and enter Normal Flying Mode, press and hold the GPS/Normal Flying Mode button to switch to Normal Flying Mode.

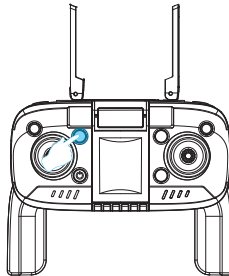



Attention: To fly in GPS Mode, please choose an open and wide open space for flight, making sure that the satellite amount is over 7.



- Please do not calibrate the compass in strong magnetic areas, such as a magnetic field, parking place or construction zones with underground reinforcement.
- Please do not carry magnetic materials with you (such as keys, cell phones, etc) when calibrating the compass.
- Please keep away from metal when calibrating the compass.

Gyroscope Calibration

When the compass calibration is finished, place the aircraft on a flat surface and follow the actions in the illustrations -Pull the throttle stick and the directional stick all the way down and to the left simultaneously. Release them after about 10 seconds. You will notice that lights on your drone will flash as you are holding down the sticks, and will stop flashing and remain illuminated once the gyroscope is calibrated.

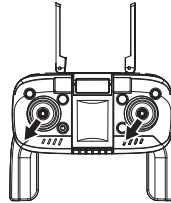
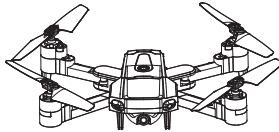

- The gyroscope comes pre-calibrated by default. The gyroscope does not need to be calibrated unless the aircraft is not initializing properly.
- Please make sure to place the aircraft on a horizontal surface when performing calibration. Failure to do this will affect the flight.

How to Lock and Unlock the Aircraft

Method 1: Move the left stick all the way down and to the right. At the same time move the right stick all the way down and to the left. (Pic 1)

Method 2: Move the left stick all the way down and to the left. At the same time move the right stick all the way down and to the right. (Pic 2)

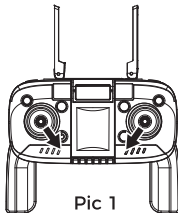

Pic 1

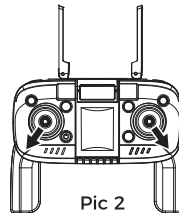

Pic 2



Tips:

- Please do not lock the aircraft by pressing the emergency button directly during the flight.
- Press the emergency button for 3 seconds to stop the flight ONLY when the aircraft encounters an emergency, or the aircraft has crashed.

Operating the Aircraft

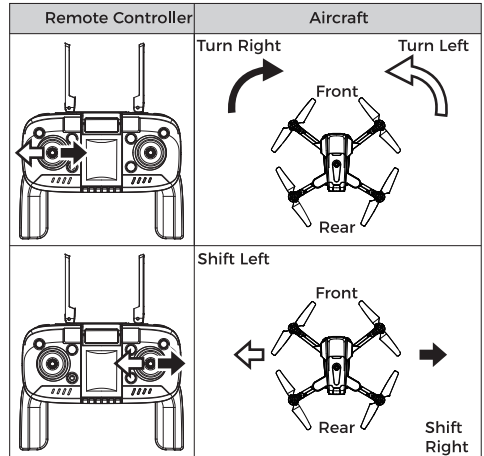
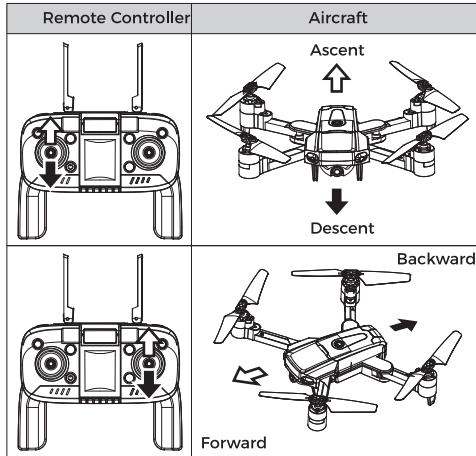

Follow Me

When activated, the Follow Me function will make the aircraft follow your smart phone's GPS location. To activate Follow Me, press and hold the Follow Me Mode button on the top left of the Remote Controller.

Note: It is important that the GPS and smart phone are correctly connected to the aircraft and that the horizontal distance between the aircraft and your smartphone is greater than 8 meters. The Follow Me function only starts after the map of your position has loaded completely.

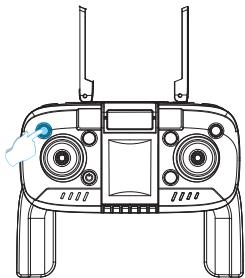

Test Flight

Basic Flight Operation Steps

1. Place the aircraft in a wide open area so that you are directly facing the front of the aircraft.
2. Turn on the aircraft and Remote Controller.
3. Connect the Remote Controller with the aircraft and then proceed to the aircraft initialization steps.
4. Connect the DRC-447 with your phone.
5. Unlock the aircraft after the gyroscope detection of the aircraft is complete.
6. Pull up the throttle stick and the aircraft takes off. Control the aircraft using the left and right sticks.
7. Pull down the throttle stick to land the aircraft.
8. Turn off the aircraft.
9. Remove the battery from the aircraft and then turn off the Remote Controller.

Video Suggestion and Tips

1. Do a pre-flight checklist.
2. Camera shooting angles can be adjusted by hand.
3. Fly in good weather with no wind.
4. Perform test flights to establish flight routes and to preview scenes.
5. Push the control stick gently to keep the aircraft movement smooth and stable.



Please keep proper operation and flight safety guidelines in mind for your own safety and others around you as well.

Important Statement

- This aircraft is not a toy. It should be assembled and operated properly. Pilots must operate this aircraft in a safe way. Improper operation may cause injury or property damage.
- This aircraft is suitable for pilots aged 14+ who have experience piloting an aircraft styled aircraft.
- The manufacturer of this product is not responsible for damages caused by misuse.
- Keep small accessories away from children and the infirm to avoid accidents.

Flight Safety Guidelines

Users should firmly uphold the principle of "safety comes first" when flying this aircraft. Never fly the aircraft near airports, above crowds or in zones storing dangerous goods and be mindful of the damage that can be caused by improper operation.

- Stay away from obstacles, crowds, power lines, trees or water.
Always choose a wide open area for every flight, well away from people and property. Never fly directly over people or animals. Don't fly in bad weather conditions, high temperature, snow, strong wind (\geq level 5), rain or fog. Maintain a 7ft (2m) distance from the aircraft when taking off and landing.

- Keep the aircraft in a dry environment.
The aircraft is composed by sophisticated electronic components and mechanical parts. To avoid damage of the mechanical and electronic components, please keep the aircraft in a dry environment and use a clean, soft cloth to wipe the surface and keep it clean.

- Practice flying together with a skilled, experienced pilot.
Beginners are recommended to practice flying with a skilled pilot's guidance. Do not fly alone.

- Keep proper operation and safe flight guidelines in mind.
Please take a careful look at this manual before flying for important information regarding the product's functions and operating tips. Stay informed of and abide strictly by relevant local laws and regulations. Keep away from any non-flight zones and respect other people's privacy.

- Safe flying
Please make sure you are in good shape mentally before every flight. Fly the aircraft as per your flying experience. Never fly under influence of alcohol or drugs. Keep the Remote Controller at least 20 cm away from your body when flying the aircraft.

- Keep distance from a flying aircraft.
Never use your hands to touch a flying aircraft under any circumstance. Don't approach and touch a landed aircraft before its propellers are completely locked.

- Keep away from heat sources

This aircraft is made of metal, fiber, plastic, electronic components and other materials. Please keep it away from heat sources to avoid deformation or even damage caused by sun exposure and high temperature.

- Environmental protection requirements

To protect our lovely planet, please recycle this aircraft as per local laws and regulations.

FCC Compliance Statement

Changes or modifications not expressly approved by the party responsible for compliance could void the user's authority to operate the equipment.

This device complies with Part 15 of the FCC Rules. Operation is subject to the following two conditions: (1) this device may not cause harmful interference, and (2) this device must accept any interference received, including interference that may cause undesired operation.

This equipment has been tested and found to comply with the limits for a Class B digital device, pursuant to Part 15 of the FCC Rules. These limits are designed to provide reasonable protection against harmful interference in a residential installation. This equipment generates, uses and can radiate radio frequency energy and, if not installed and used in accordance with the instructions, may cause harmful interference to radio communications. However, there is no guarantee that interference will not occur in a particular installation.

If this equipment does cause harmful interference to radio or television reception, which can be determined by turning the equipment off and on, the user is encouraged to try to correct the interference by one or more of the following measures:

- Reorient or relocate the receiving antenna.
- Increase the separation between the equipment and receiver.
- Connect the equipment into an outlet on a circuit different from that to which the receiver is connected.
- Consult the dealer or an experienced radio/TV technician for help.

VIVITAR 1 YEAR WARRANTY

This warranty covers the original consumer purchaser only and is not transferable.

This warranty covers products that fail to function properly UNDER NORMAL USAGE, due to defects in material or workmanship. Your product will be repaired or replaced at no charge for parts or labor for a period of one year.

What Is Not Covered by Warranty

Damages or malfunctions not resulting from defects in material or workmanship and damages or malfunctions from other than normal use, including but limited to, repair by unauthorized parties, tampering, modification or accident.

To Obtain Warranty Service and Troubleshooting Information:

Call 1-800-592-9541 in the U.S. or visit our website at www.vivitar.com.

Sakar International Inc

195 Carter Drive Edison, NJ, 08817, USA

To receive Warranty service along with the name and address of an authorized product service center, the original consumer purchaser must contact us for problem determination and service procedures. Proof of purchase in the form of a bill of sale or receipted invoice, evidencing that the product is within the applicable Warranty period(s), MUST be presented in order to obtain the requested service. It is your responsibility to properly package and send any defective products along with a dated copy of proof of purchase, a written explanation of the problem, and a valid return address to the authorized service center at your expense. Do not include any other items or accessories with the defective product. Any products received by the authorized service center that are not covered by warranty will be returned unrepai red.

